



H320

- **Wiring diagram**

H320WD2H/1/1

TABLE OF CONTENTS

1.	Diagram of battery, ignition switch and load relay circuit	2
2.	Engine compartment fuse box layout	3
3.	Dashboard fuse box layout.....	4
4.	Diagram No. 2 of MT electronic injection unit circuit	5
5.	Diagram No. 1 of MT electronic injection unit circuit	6
6.	Diagram of generator and starter circuit.....	7
7.	Diagram of horn, radiator fan and fuel pump circuit	8
8.	Diagram of wiper blade control switch, rear wiper controller, front wiper motor and washing fluid pump circuit.....	9
9.	Diagram of power A/C control unit, blower and rear demist circuit	10
10.	Diagram of radio cassette, steering wheel volume switch, electronic clock and lighter circuit.....	11
11.	Diagram of dual-loop air bag and 6-loop air bag circuit.....	12
12.	Diagram of ABS circuit.....	13
13.	Diagram of back radar and power rearview mirror circuit.....	14
14.	Diagram of light control switch circuit.....	15
15.	Diagram of front headlamp and side turning lamp circuit.....	16
16.	Diagram of rear tail light, high-mounted brake lamp, license plate lamp, interior ceiling lamp and sunroof controller circuit	17
17.	Diagram of brake oil level sensor, hand brake, seat belt buckle, engine oil pressure sensor, water temperature sensor and diagnostic interface (MT car speed sensor) circuit.....	18
18.	Diagram of glass riser switch and glass riser motor circuit.....	19
19.	Diagram of front door central control switch, door lock motor, alarm lamp module and door micro-switch circuit	20
20.	Diagram of BCM circuit.....	21
21.	Diagram of manual A/C control unit, blower and rear demister circuit	22
22.	Diagram No. 1 of 1.6AT electronic injection unit circuit.....	23
23.	Diagram No. 2 of 1.6AT electronic injection unit circuit.....	24
24.	Diagram No. 3 of 1.6AT electronic injection unit circuit.....	25
25.	Diagram No. 4 of 1.6AT electronic injection unit circuit.....	26
26-27.	Details of connector naming	27
28-29.	Details of electrical appliance naming	29

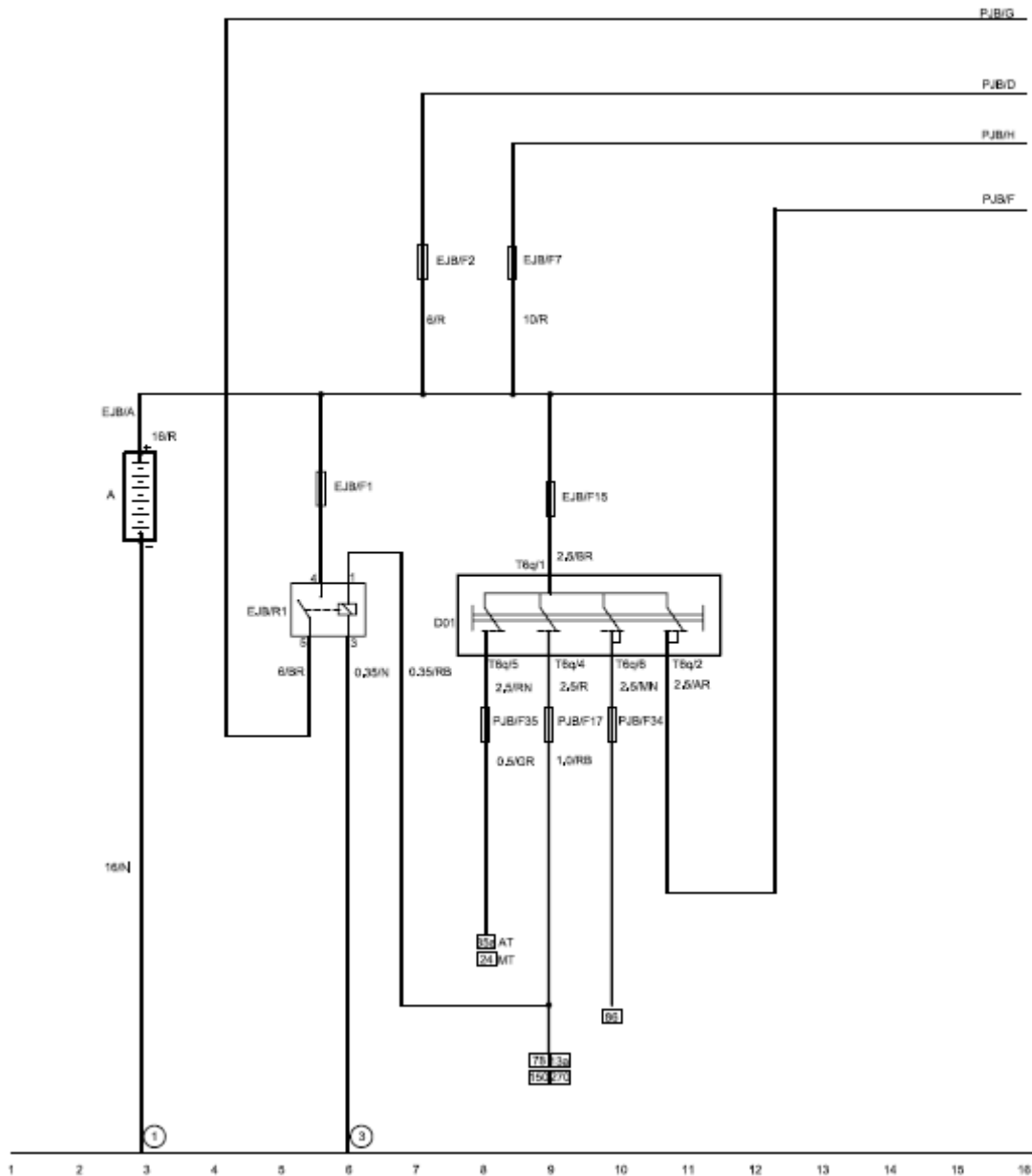

1. Diagram of battery, ignition switch and load relay circuit

- A- battery
- D01- ignition switch
- T6q- ignitions witch connector, 6-hole, white
- EJB A- connection, engine compartment fuse box to the positive pole of battery
- EJB- engine compartment fuse box
- PJB- dashboard fuse box
- PJB D- connection, dashboard fuse box stud
- PJB G- connection, dashboard fuse box stud
- PJB F- connection, dashboard fuse box stud
- PJB H- connection, dashboard fuse box stud
- ①- negative pole of battery to the earth point on the car body
- ③- earth point on the FL engine compartment

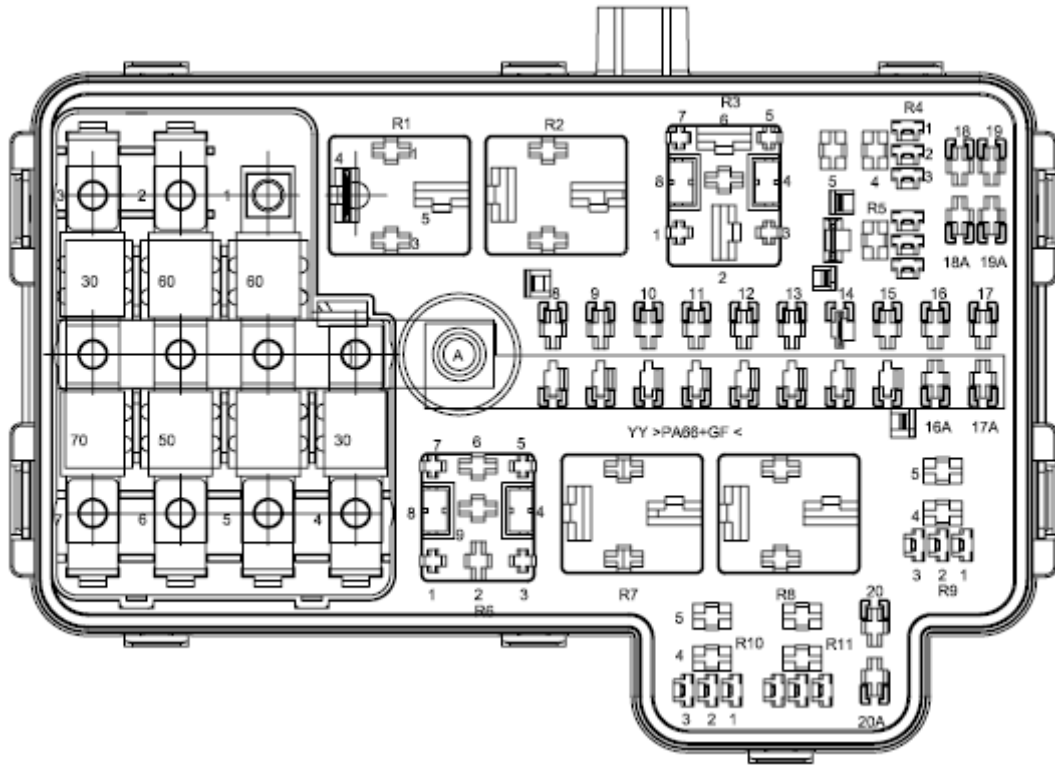

EJB

Item			Item		
F1	Load relay fuse	60A	R1	Load relay	70A
F2	KL30 to PJB D	60A	R2	Cooling fan low-speed relay	40A
F3	ABS pump motor fuse	30A	R3		
F4	ABS solenoid valve power supply fuse	30A	R4	Main relay	30A
F5			R5	Horn relay	30A
F6	Radiator fan fuse	50A	R6		
F7	KL30 to PJB H	70A	R7	Start relay	40A
F8	Fuel pump fuse	15A	R8	Cooling fan high-speed relay	40A
F9	Start relay fuse	30A	R9	AT controller relay	30A
F10	Main relay fuse	30A	R10	Fuel pump relay	30A
F11	A/C compressor fuse	10A	R11	A/C compressor relay	30A
F12					
F13	A/T relay fuse	15A			
F14	Horn fuse	10A			
F15	Ignition switch fuse	30A			
F16	Engine ECU fuse (AT)	15A			
F16	Engine ECU fuse (MT)	20A			
F17	Oxygen sensor fuse (MT)	15A			
F17	Oxygen sensor fuse (AT)	10A			
F18	Main relay control power supply fuse (MT)	15A			
F19	Immobilizer fuse	10A			
F20	Nozzle fuse	10A			
FU	Generator fuse	100A			

2. Engine compartment fuse box layout

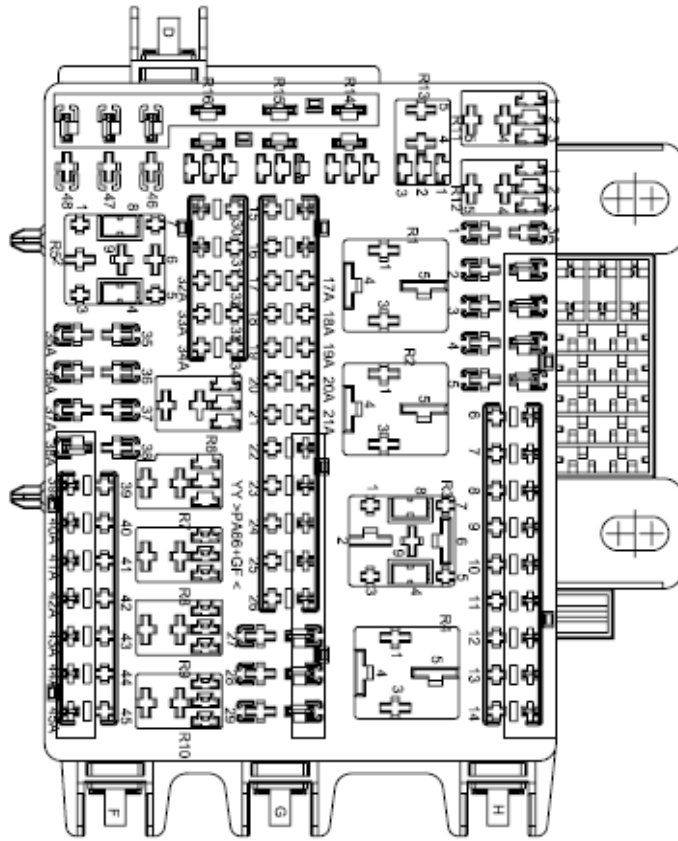

PJB

Item			Item		Item			
F1			F26	Lighter fuse	15A	R1	Rear demist relay	70A
F2	Rear demist fuse	30A	F27			R2	Blower high-speed relay	40A
F3	BCM controller 1	30A	F28			R3		
F4	BCM controller 2	30A	F29			R4		
F5	BCM controller 3	20A	F30	FL high beam fuse	10A	R5		
F6	Radio cassette fuse	10A	F31	FR high beam fuse	10A	R6	Blower low-speed relay	30A
			F32			R7		
F8	Diagnostic interface fuse	10A	F33			R8	Washing fluid pump relay	30A
F9	Interior lamp fuse	5A	F34	Ignition switch signal fuse	7.5A	R9		
F10	Sunroof fuse	15A	F35	Engine start fuse	10A	R10		
F11			F36			R11	Front fog light relay	30A
F12			F37			R12		
F13	Front fog light fuse	15A	F38	Ignition coil fuse (MT)	15A	R13		
F14	ECU power supply (AT)	5A	F38	Shift device fuse (AT)	10A	R14	Low beam relay	30A
F15	RH low beam fuse	10A	F39	Air bag fuse	7.5A	R15	High beam relay	30A
F16	LH low beam fuse	10A	F40	Speed sensor fuse (MT)	10A	R16	Overdrive relay	30A
F17	Ignition switch power supply fuse	10A	F41	Ignition switch power supply fuse	10A			
F18	LH position lamp fuse	10A	F42	Back switch (MT)	5A			
F19	RH position lamp fuse	10A	F42	Ignition coil fuse (AT)	15A			
F20	Back lamp fuse (AT)	10A	F43	ABS controller fuse	10A			
F21			F44	Brake switch fuse	10A			
F22	Washing fluid pump fuse	15A	F45	Ignition switch power supply fuse	7.5A			
F23	Signal fuse	5A	F46	Light combination switch fuse	20A			
F24	Wiper control switch fuse	15A	F47	Blower fuse	30A			
F25	Rear wiper controller fuse	15A	F48					

3. Dashboard fuse box layout

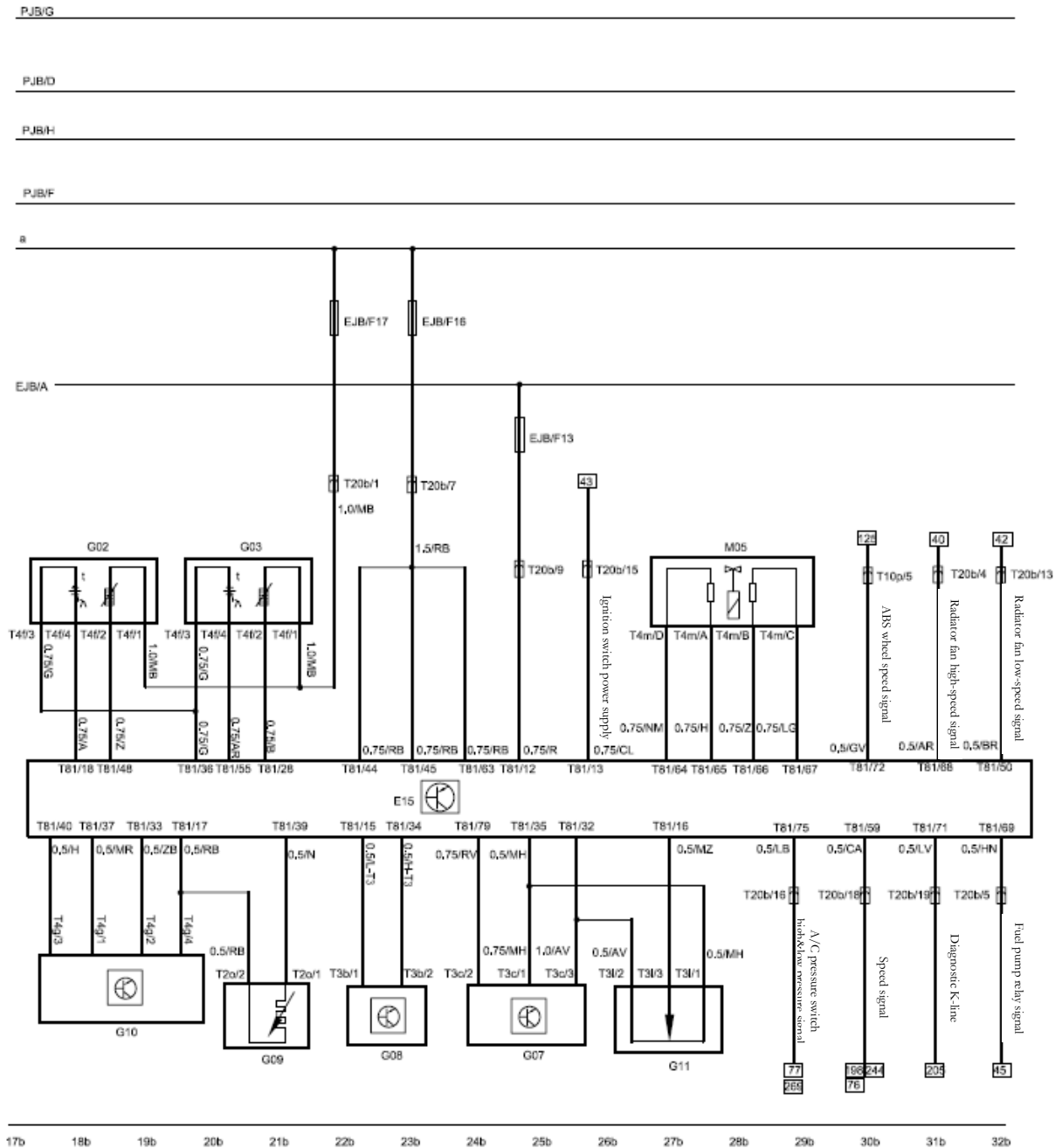

4. Diagram No. 2 of MT electronic injection unit circuit

- | | | | |
|--------|--|--------|---|
| a- | main relay power supply | T3c- | camshaft position sensor connector, 3-hole |
| E15- | MT engine ECU | G11- | throttle valve position sensor |
| G09- | water temperature 1 | T20b- | connector of electronic injection cable and main cable, 20-hole, black |
| G02- | front oxygen sensor | T4f- | MT oxygen sensor connector, 4-hole |
| G03- | rear oxygen sensor | T4m- | MT stepper motor connector, 4-hole |
| T81- | MT electronic injection ECU connection, 81-hole, | T10p- | connector of MT electronic injection cable and main cable, 10-hole, black |
| black | | PJB D- | connection, dashboard fuse box stud |
| T2o- | water temperature sensor connector, 2-hole | PJB G- | connection, dashboard fuse box stud |
| G07- | camshaft position sensor | PJB F- | connection, dashboard fuse box stud |
| G08- | crankshaft position sensor | PJB H- | connection, dashboard fuse box stud |
| G10- | air flow rate sensor | EJB- | engine compartment fuse box |
| T3i- | MT throttle valve position sensor connector, | PJB- | dashboard fuse box |
| 3-hole | | EJB A- | connection, engine compartment fuse box |
| M05- | stepper motor | | connected to positive pole of battery |
| T4g- | air flow rate sensor connector, 4-hole | | |
| T3b- | crankshaft position sensor connector, 3-hole | | |

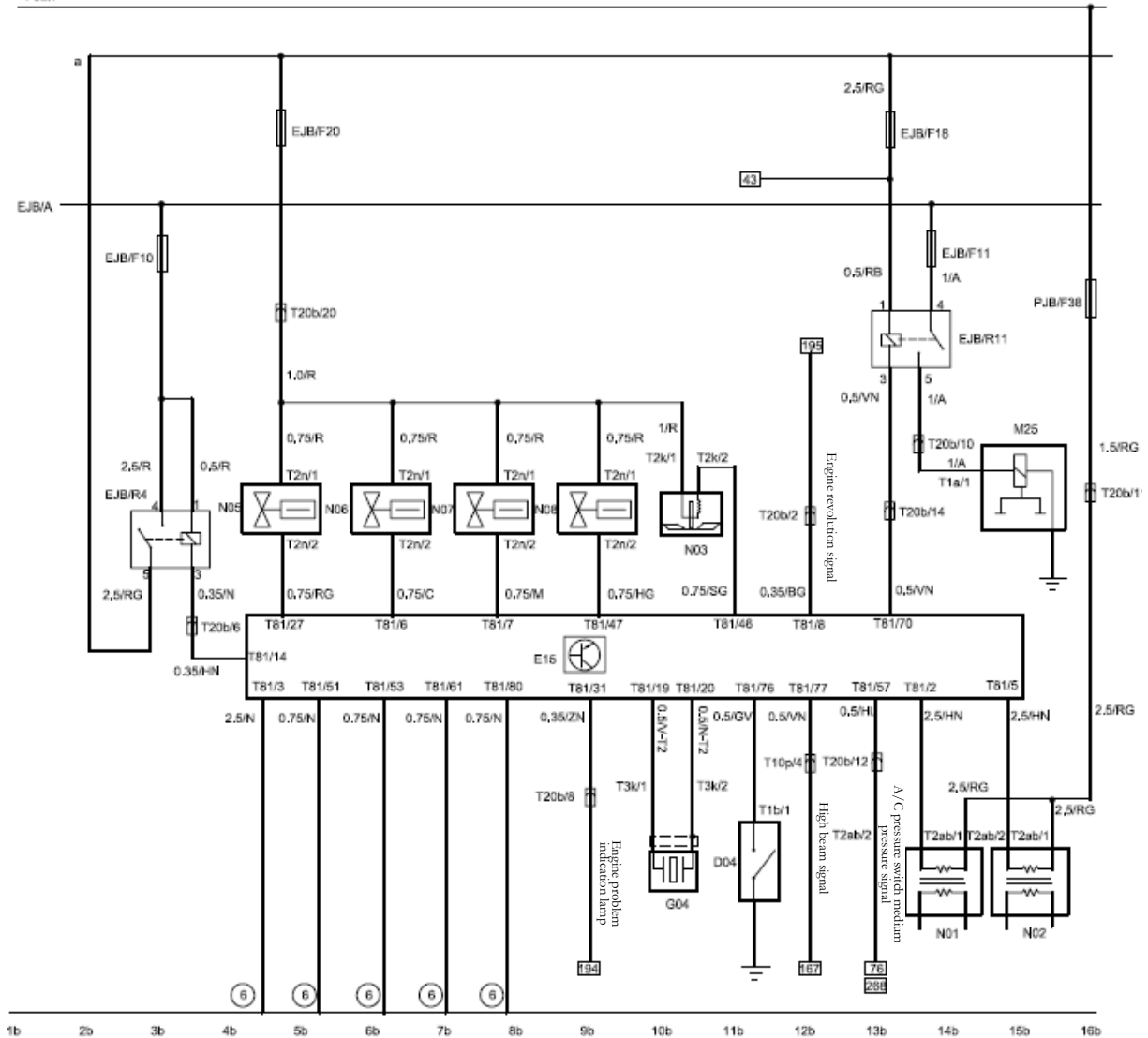

5. Diagram No. 1 of MT electronic injection unit circuit

a-	main relay power supply	N01-	ignition coil 2/3
E15-	MT engine ECU	N02-	ignition coil 1/4
T20b-	connector of electronic injection cable and main cable, 20-hole, black	T1a-	A/C compressor connector, 1-hole, gray
T2n-	nozzle connector, 2-hole	T2ab-	MT ignition coil connector, 2-hole, black
T81-	MT electronic injection ECU connector, 81-hole, black	T1b-	power steering switch connector, 1-hole
		Ⓞ-	earth point of MT electronic injection cable in the water trough
N03-	canister solenoid valve	PJB D-	connection, dashboard fuse box stud
N05-	nozzle 1	PJB G-	connection, dashboard fuse box stud
N06-	nozzle 2	PJB F-	connection, dashboard fuse box stud
N07-	nozzle 3	PJB H-	connection, dashboard fuse box stud
N08-	nozzle 4	EJB-	engine compartment fuse box
T2k-	canister solenoid valve connector, 2-hole	PJB-	dashboard fuse box
T3k-	knock sensor connector, 3-hole, black	EJB A-	connection, engine compartment fuse box connected to positive pole of battery
M25-	A/C compressor		
G04-	knock sensor		
D04-	power steering switch		

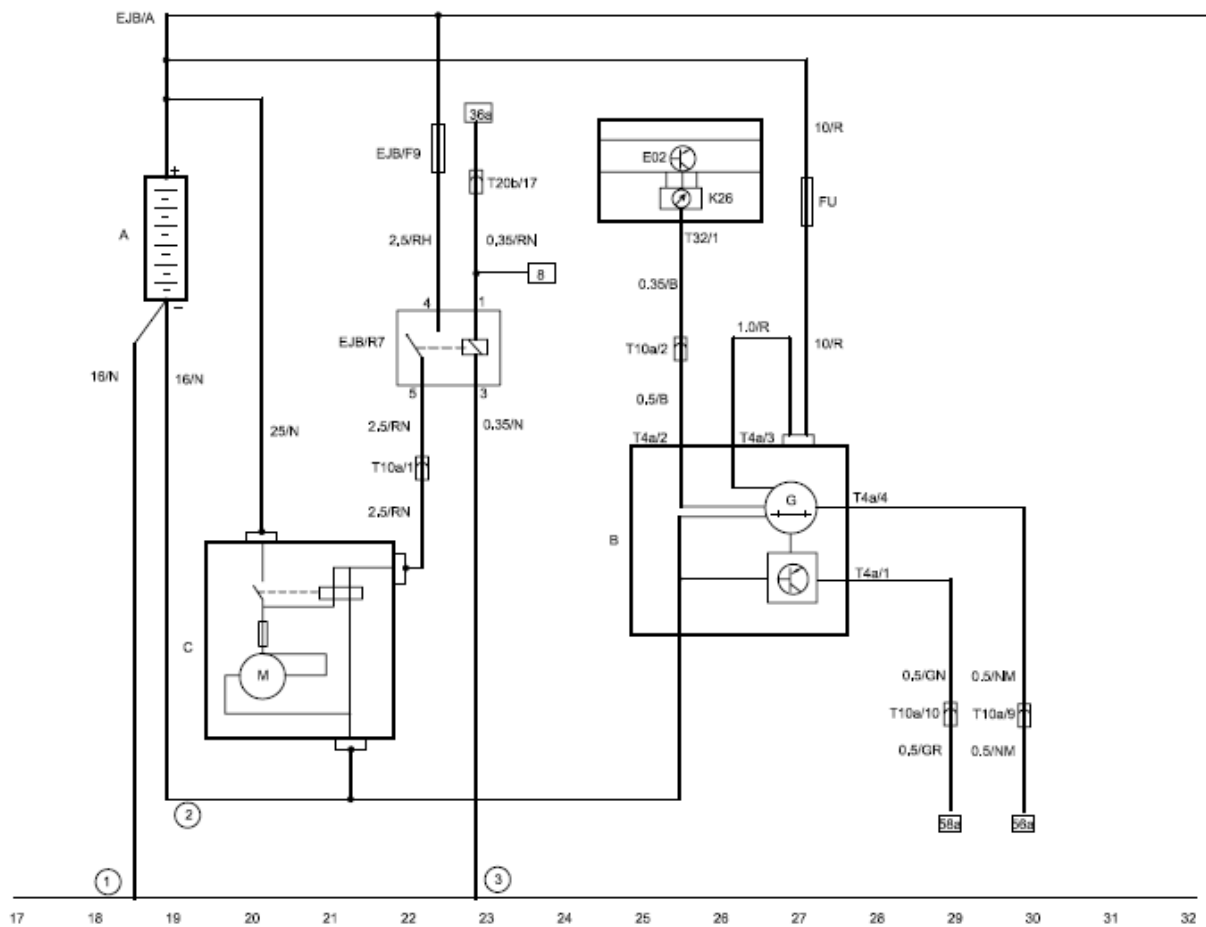

6. Diagram of generator and starter circuit

A-	battery	K26-	generator charging indication lamp in combination instrument
B-	generator	E02-	combination instrument
C-	starter	T32-	combination instrument connector, 32-hole, blue connection, dashboard fuse box stud
EJB A-	connection, engine compartment fuse box connected to positive pole of battery	PJB D-	connection, dashboard fuse box stud
EJB-	engine compartment fuse box	PJB G-	connection, dashboard fuse box stud
PJB-	dashboard fuse box	PJB F-	connection, dashboard fuse box stud
FU-	fuse from generator to battery	PJB H-	connection, dashboard fuse box stud
T20b-	connector of electronic injection cable and main cable, 20-hole, black	③-	earth point on FL engine compartment
T10a-	connector of battery cable to main cable, 10-hole, black	①-	body
T4a-	generator connector, 4-hole, gray	②-	negative pole of battery to engine

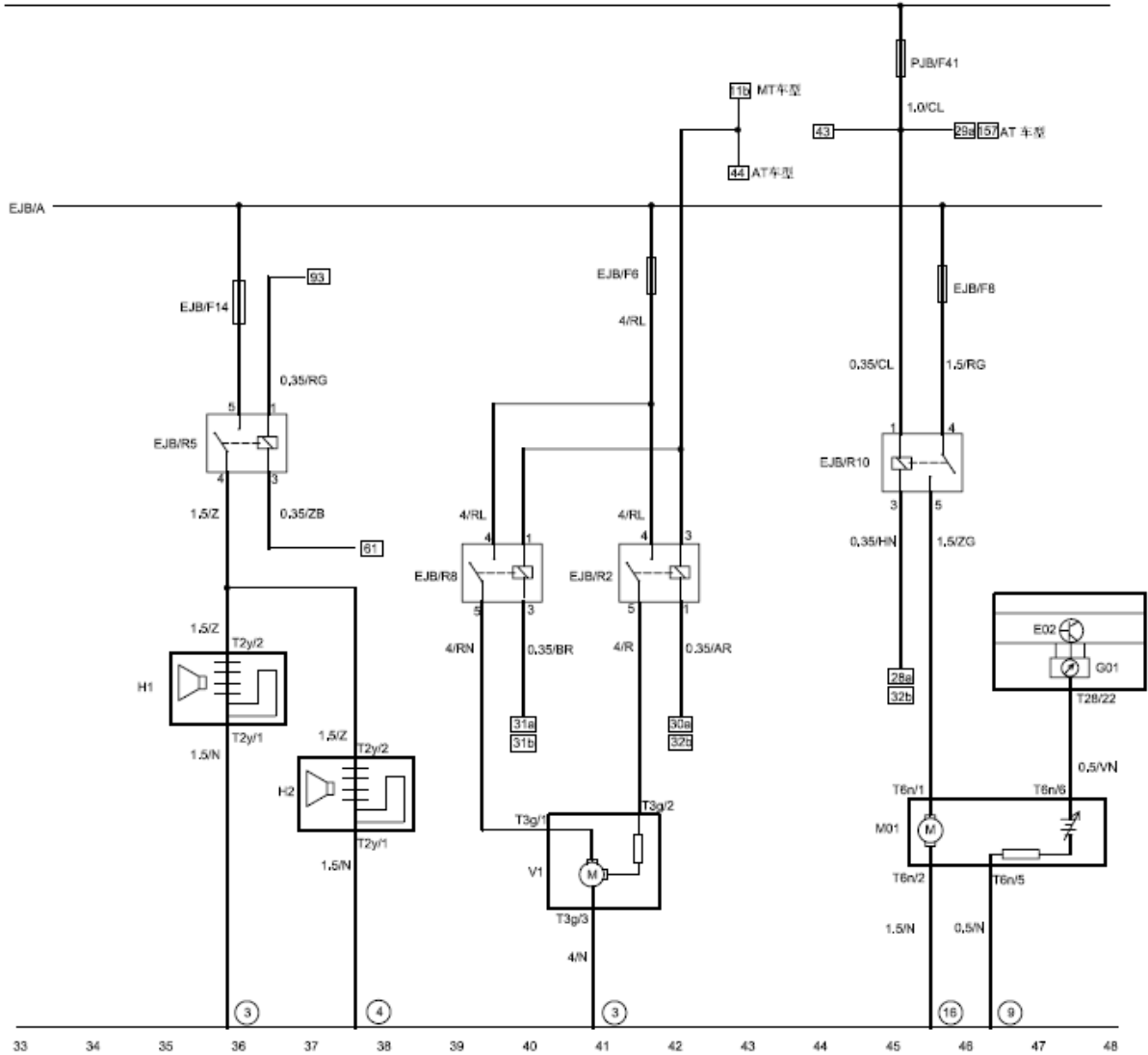

7. Diagram of horn, radiator fan and fuel pump circuit

M01-	fuel pump and fuel level sensor	H2-	FR horn
H1-	FL horn	PJB D-	connection, dashboard fuse box stud
T2y-	horn connector, 2-hole, black	PJB G-	connection, dashboard fuse box stud
V1-	radiator cooling fan	PJB F-	connection, dashboard fuse box stud
EJB-	engine compartment fuse box	PJB H-	connection, dashboard fuse box stud
PJB-	dashboard fuse box	EJB-	engine compartment fuse box
T28-	combination instrument connector, 28-hole, black	PJB-	dashboard fuse box
T3g-	fan connector, 3-hole, black	EJB A-	connected to positive pole of battery
T6n-	fuel pump connector, 6-hole, brown	③-	earth point on FL engine compartment
T20b-	connector of electronic injection cable and main cable, 20-hole, black	④-	earth point on FR engine compartment
E02-	combination instrument	○,16-	Lower earth point of main cable on RR seat
G01-	fuel level indication in combination instrument	⑨-	lower earth point of main cable on RH pillar A

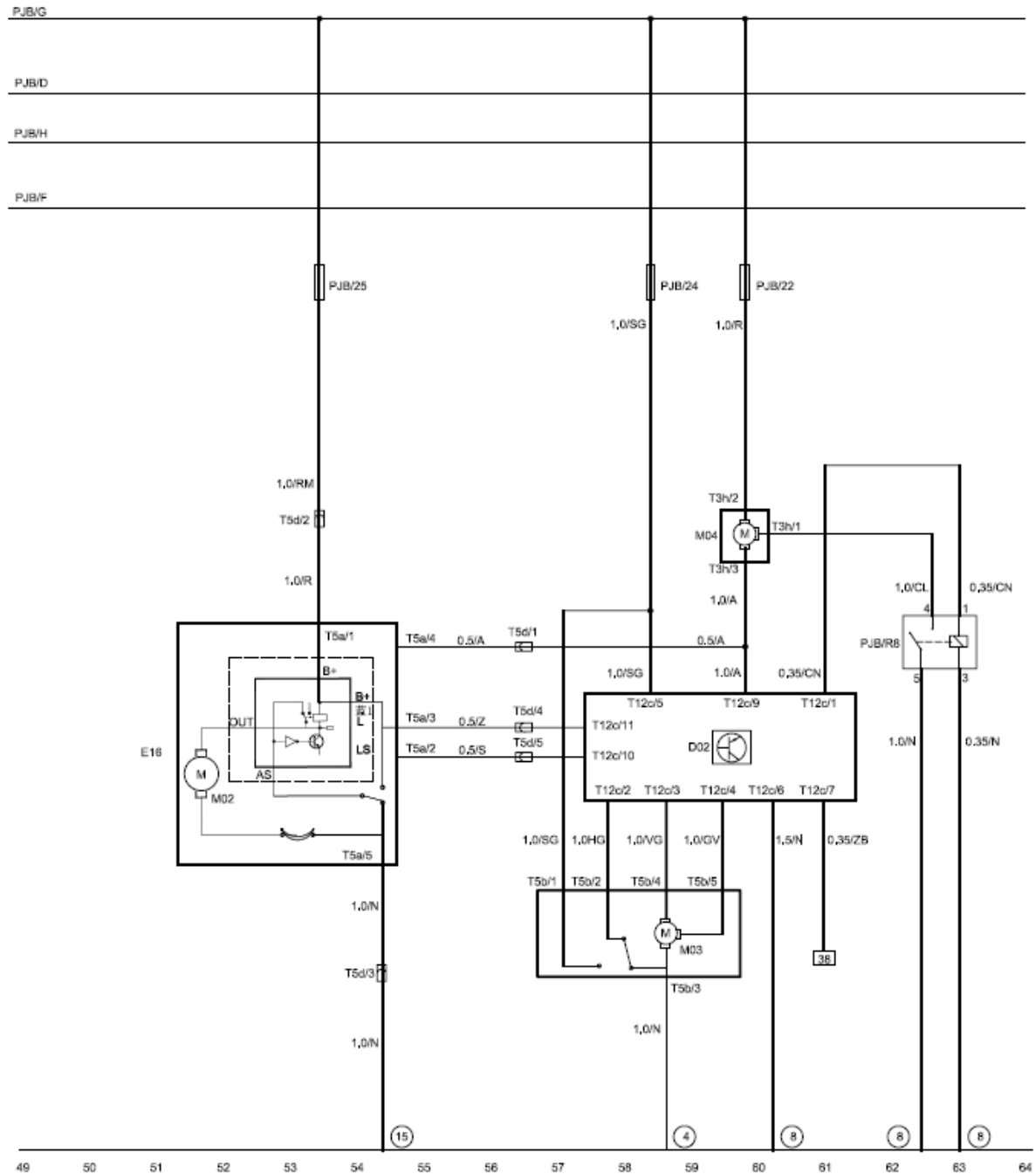

8. Diagram of wiper blade control switch, rear wiper controller, front wiper motor and washing fluid pump circuit

- | | | | |
|-------|---|--------|--|
| M02- | rear windshield wiper motor | ○,15- | Lower earth point of main cable on RL seat |
| D02- | wiper switch | ④- | earth point on FR engine compartment |
| M03- | front windshield wiper motor | ⑧- | lower earth point of main cable on LH pillar A |
| M04- | washing fluid pump motor | PJB D- | connection, dashboard fuse box stud |
| E16- | rear wiper controller and motor | PJB G- | connection, dashboard fuse box stud |
| T5d- | connector of LH tail gate cable and main cable, 5-hole, brown | PJB F- | connection, dashboard fuse box stud |
| T5a- | rear wiper controller connector, 5-hole, gray | PJB H- | connection, dashboard fuse box stud |
| T5b- | front wiper motor connector, 5-hole, black | EJB- | engine compartment fuse box |
| T12c- | wiper switch connector, 12-hole, white | PJB- | dashboard fuse box |
| T3h- | washing fluid pump motor connector, 3-hole, black | EJB A- | connection, engine compartment fuse box |
| | | | connected to positive pole of battery |

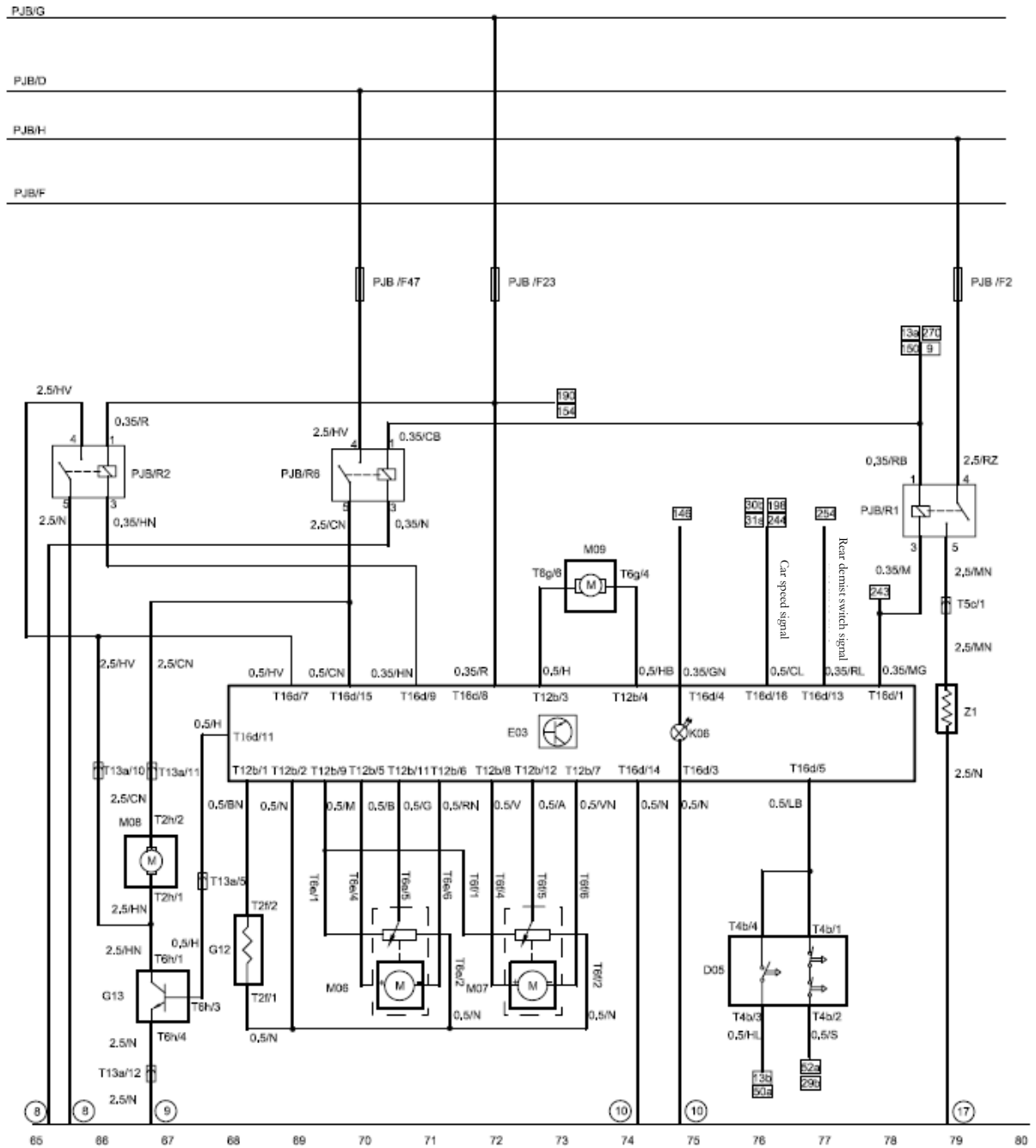

9. Diagram of power A/C control unit, blower and rear demist circuit

- | | | | |
|-------|---|--------|--|
| T13a- | connector of main cable and power A/C cable, 13-hole, | ⑨- | lower earth point of main cable on RH pillar A |
| T4b- | A/C pressure switch connector, 4-hole, green | ⑩- | earth point on dashboard cross member |
| T5c- | connector of main cable and LH tail gate cable, 5-hole, | ④- | earth point on FR engine compartment |
| black | | ○, 17- | earth point of main cable on RH pillar C |
| K06- | A/C control unit background light illumination | E03- | power A/C control unit |
| T16d- | A/C ECU connector, 16-hole, black | M06- | mixer air gate motor |
| T12b- | A/C ECU connector, 12-hole, black | M07- | air out module motor |
| T2f- | A/C evaporator sensor connector, 2-hole, white | D05- | A/C three-state pressure switch |
| T6g- | fresh air/circulation module motor connector, 6-hole, | M08- | blower motor |
| green | | PJB D- | connection, dashboard fuse box stud |
| T6h- | blower motor connector, 2-hole, white | PJB G- | connection, dashboard fuse box stud |
| T63- | blower speed regulation resistor connector, 6-hole, | PJB F- | connection, dashboard fuse box stud |
| white | | PJB H- | connection, dashboard fuse box stud |
| T6f- | A/C air out module motor connector, 6-hole, green | EJB- | engine compartment fuse box |
| M09- | fresh air/circulation air module motor | PJB- | dashboard fuse box |
| G12- | evaporator temperature sensor | EJB A- | connection, engine compartment fuse box connected to |
| G13- | blower speed regulation resistor | | positive pole of battery |
| ⑧- | lower earth point of main cable on LH pillar A | | |

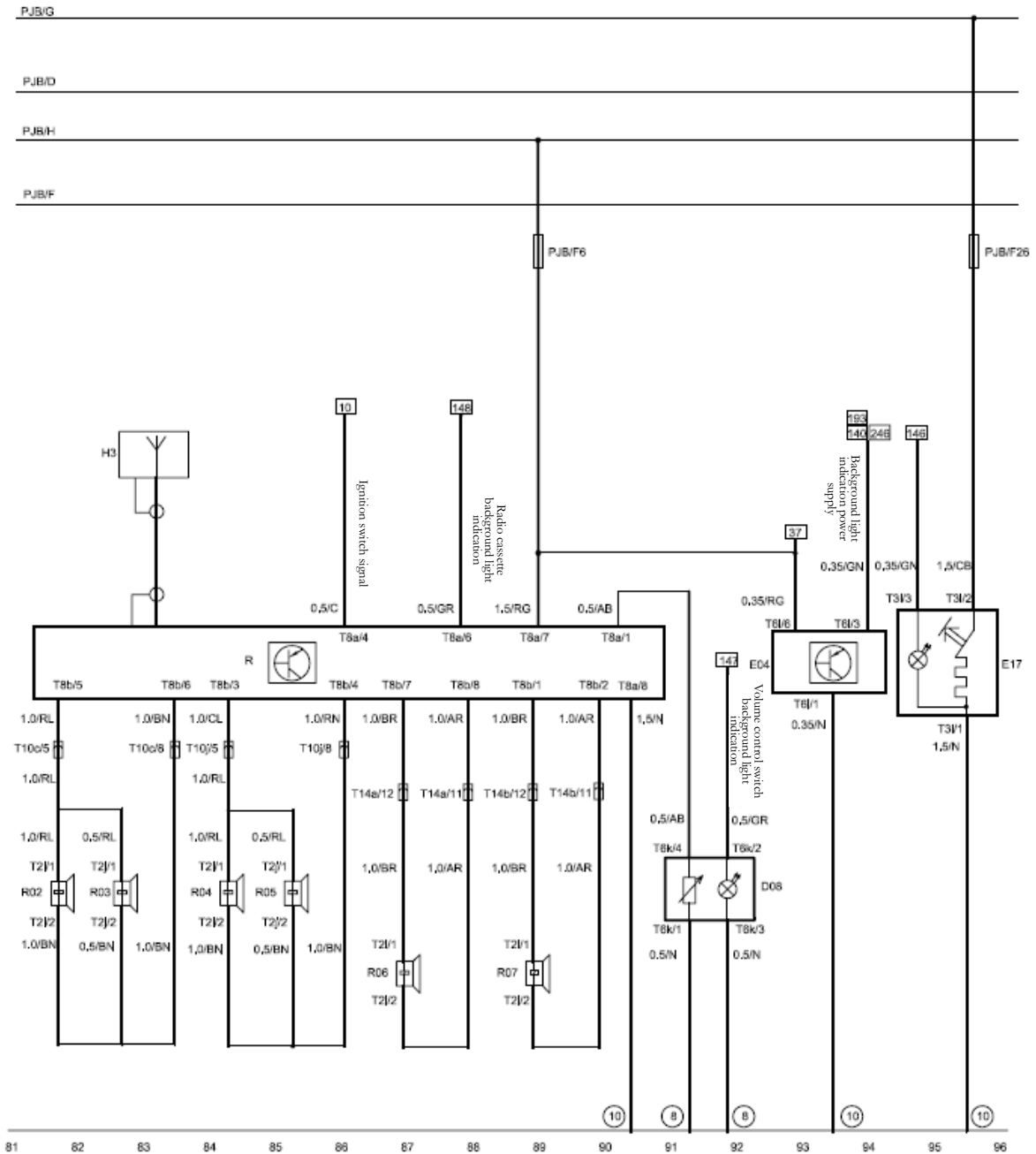

10. Diagram of radio cassette, steering wheel volume switch, electronic clock and lighter circuit

T10c-	connector B of FL door cable and dashboard main cable, 10-hole	R03-	FL door treble speaker
T6k-	steering wheel volume adjusting switch connector, 6-hole, black	R04-	FR door bass speaker
T6l-	electronic clock connector, 6-hole, black	R05-	FR door treble speaker
H3-	radio cassette antenna	R06-	RL door bass speaker
T10j-	connector B of FR door cable and dashboard main cable, 10-hole	R07-	RR door bass speaker
T8a-	radio cassette connector A, 8-hole	R08-	steering wheel radio cassette volume control switch
T8b-	radio cassette connector B, 8-hole	E17-	lighter
T14a-	connector of RL door to main cable, 14-hole, white	T3l-	lighter connector, 3-hole, white
T14b-	connector of RR door to main cable, 14-hole, white	E04-	electronic clock
Ⓢ-	lower earthing point of main cable on LH pillar A	PJB D-	connection, dashboard fuse box stud
⑩-	earth point on dashboard cross member	PJB G-	connection, dashboard fuse box stud
T2i-	bass speaker connector, 2-hole, black	PJB F-	connection, dashboard fuse box stud
T2j-	treble speaker connector, 2-hole, black	PJB H-	connection, dashboard fuse box stud
R-	radio cassette	EJB-	engine compartment fuse box
R02-	FL door bass speaker	PJB-	dashboard fuse box
		EJB A-	connection, engine compartment fuse box connected to positive pole of battery

PJB/G

PJB/D

PJB/H

PJB/F

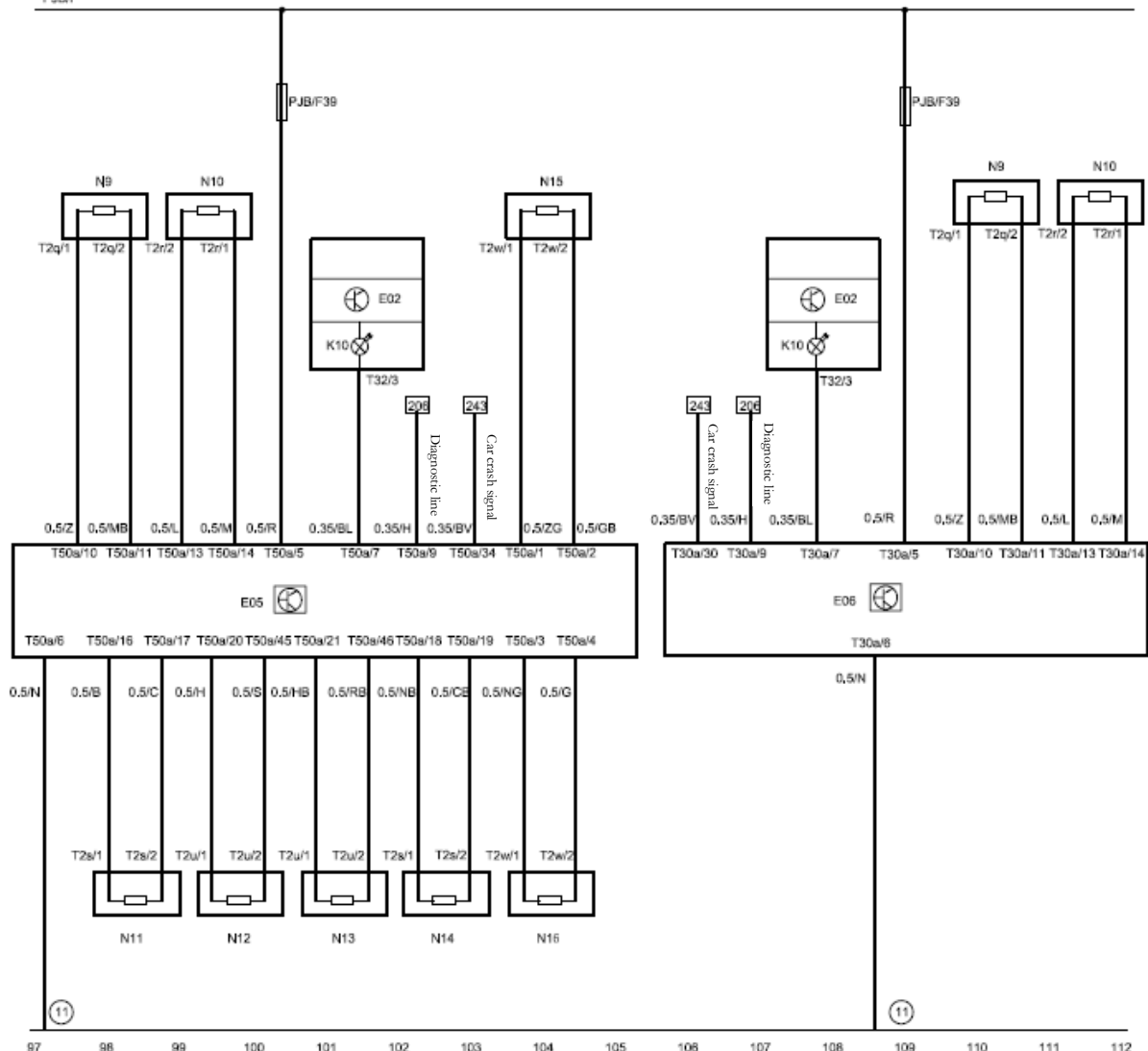

11. Diagram of dual-loop air bag and 6-loop air bag circuit

- | | | | |
|-------|---|------------|--|
| E05- | 6-loop air bag ECU | instrument | |
| E06- | double-loop air bag | E02- | combination instrument |
| N9- | driver's air bag trigger | T32- | combination instrument connector, 32-hole, blue |
| N10- | front passenger's air bag trigger | T2s- | side air bag trigger connector, 2-hole, yellow |
| N11- | driver's side air bag trigger | T2u- | side air bag sensor connector, 2-hole, yellow |
| N12- | driver's side air bag sensor | T2w- | seat belt pre-tightening connector, 2-hole, yellow |
| N13- | front passenger's side air bag sensor | ○,11- | air bag ECU earth point |
| N14- | front passenger's side air bag trigger | PJB D- | connection, dashboard fuse box stud |
| T50a- | 6-loop air bag ECU connector, 50-hole, yellow | PJB G- | connection, dashboard fuse box stud |
| T30a- | double-loop air bag ECU connector, 30-hole, yellow | PJB F- | connection, dashboard fuse box stud |
| T2q- | driver's air bag trigger connector, 2-hole, yellow | PJB H- | connection, dashboard fuse box stud |
| T2r- | front passenger's air bag trigger connector, 2-hole, yellow | EJB- | engine compartment fuse box |
| N16- | front passenger's side seat belt pre-tightening device | PJB- | dashboard fuse box |
| N15- | driver's side seat belt pre-tightening device | EJB A- | connection, engine compartment fuse box connected to |
| K10- | air bag problem indication lamp in combination | | positive pole of battery |

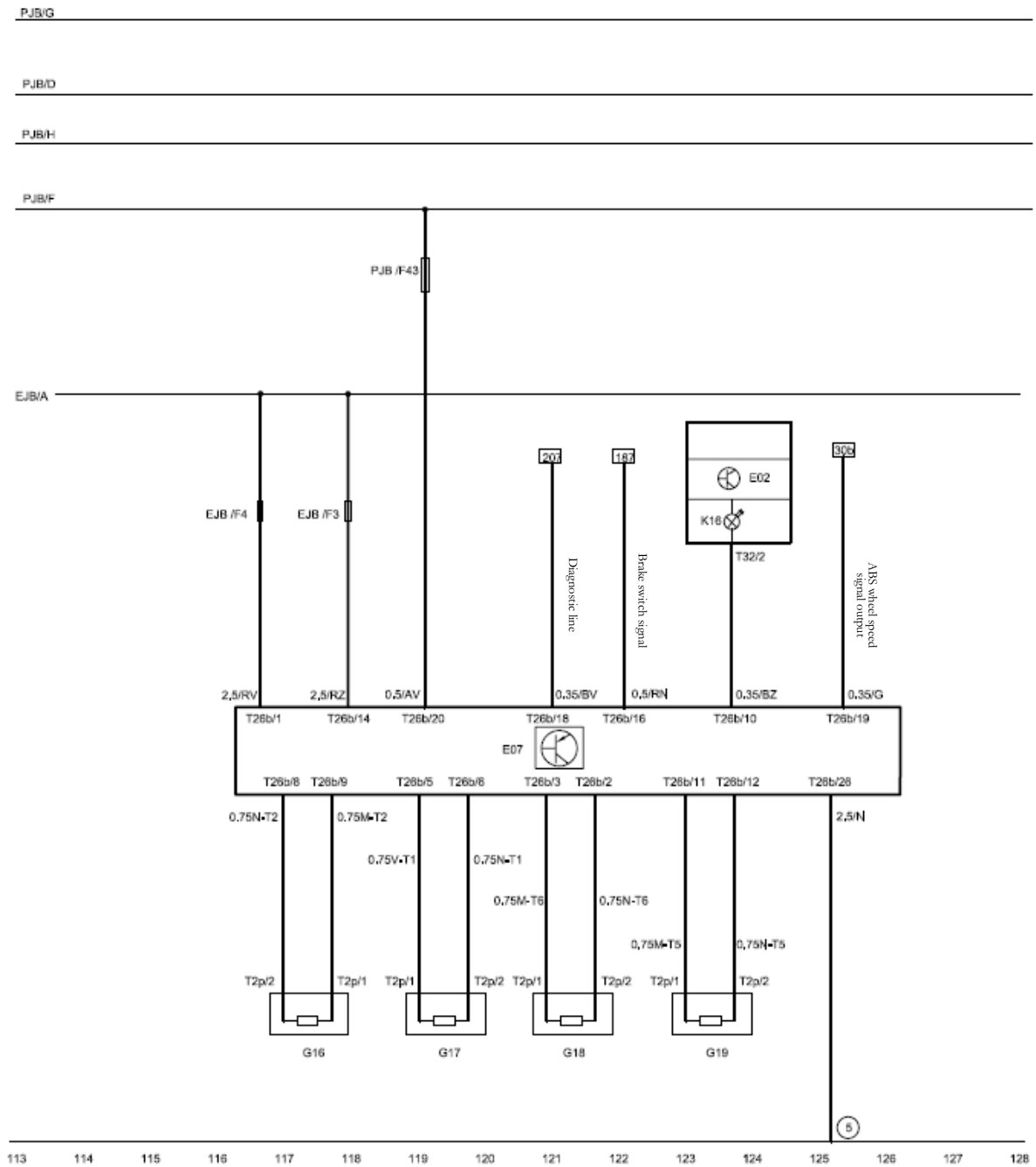

12. Diagram of ABS circuit

E07-	ABS ECU
G16-	FL wheel speed sensor
G17-	FR wheel speed sensor
G18-	RL wheel speed sensor
G19-	RR wheel speed sensor
E02-	combination instrument
T32-	combination instrument connector, 32-hole, blue
K16-	combination instrument ABS problem indication lamp
T2p-	ABS sensor connector, 2-hole, black
T26b-	ABS ECU connector, 26-hole, black
⑤-	ABS earth point in the water trough
PJB D-	connection, dashboard fuse box stud
PJB G-	connection, dashboard fuse box stud
PJB F-	connection, dashboard fuse box stud
PJB H-	connection, dashboard fuse box stud
EJB-	engine compartment fuse box
PJB-	dashboard fuse box
EJB A-	connection, engine compartment fuse box connected to positive pole of battery

PJB/G

PJB/D

PJB/H

PJB/F

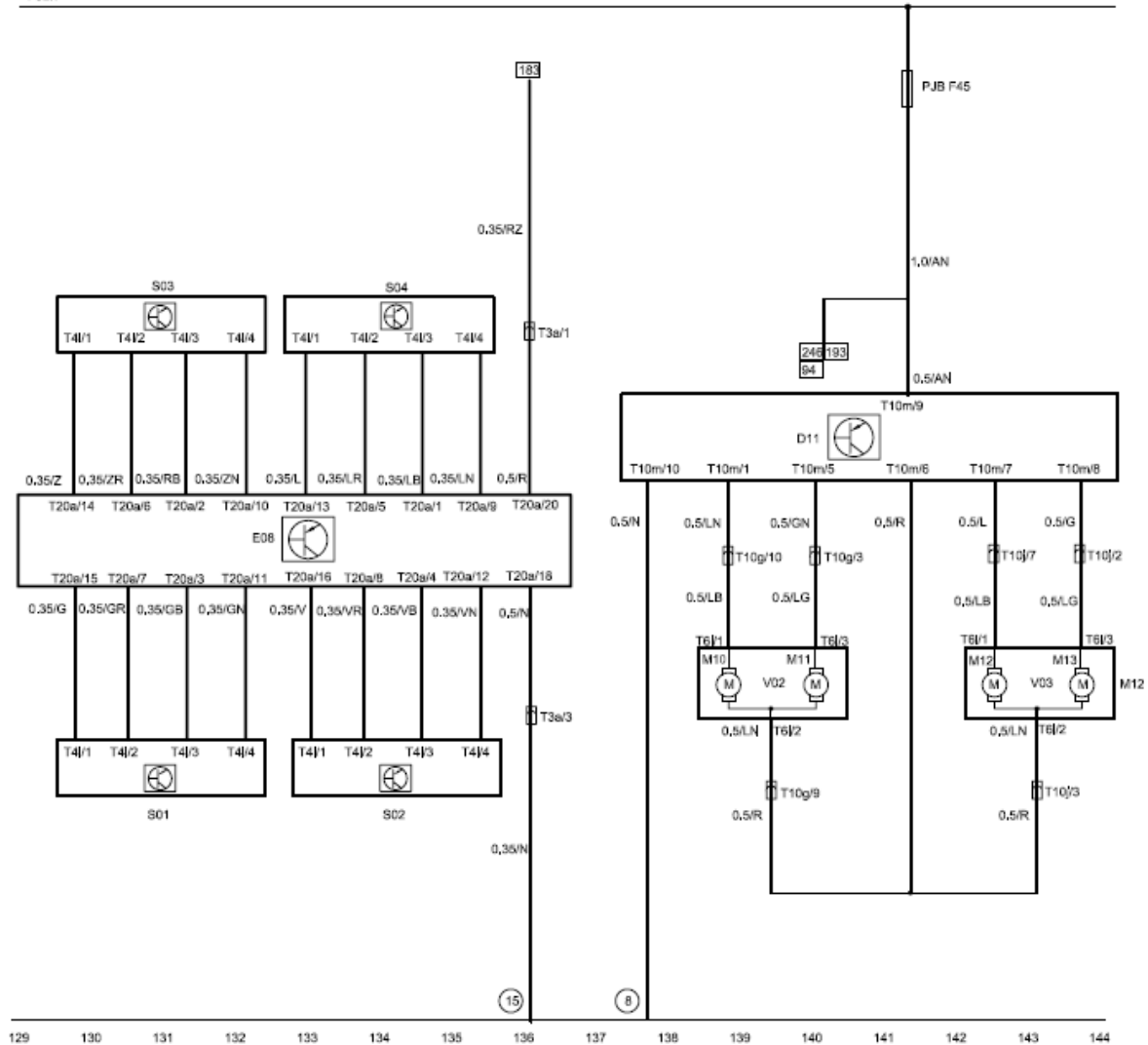

13. Diagram of back radar and power rearview mirror circuit

- E08- back radar ECU
- D11- power rearview mirror switch
- S01- back radar sensor 1 (from left to right)
- S02- back radar sensor 2 (from left to right)
- S03- back radar sensor 3 (from left to right)
- S04- back radar sensor 4 (from left to right)
- V02- FL door power rearview mirror
- V03- FR door power rearview mirror
- T10g- connector C of FL door cable and dashboard main cable, 10-hole
- T20a - back radar ECU connector, 20-hole, black
- T3a- connector of main cable and back radar cable, 3-hole, white
- T10m- power rearview mirror switch connector, 10-hole, white
- T10j- connector of FR door cable and dashboard main cable, 10-hole, white

- Ⓢ- lower earth point of main cable on LH pillar A connection, dashboard fuse box stud
- PJB D- connection, dashboard fuse box stud
- PJB G- connection, dashboard fuse box stud
- PJB F- connection, dashboard fuse box stud
- PJB H- connection, dashboard fuse box stud
- EJB- engine compartment fuse box
- PJB- dashboard fuse box
- M10- RL rearview mirror left & right adjusting motor
- M11- RL rearview mirror up & down adjusting motor
- M12- RR rearview mirror left & right adjusting motor
- M13- RR rearview mirror up & down adjusting motor
- T4l- back radar sensor connector, 4-hole, green
- T6i- power rearview mirror connector, 6-hole, white
- T10g- connector of FL door cable and dashboard main cable, 10-hole, orange
- ,15- Lower earth point of main cable on RL seat

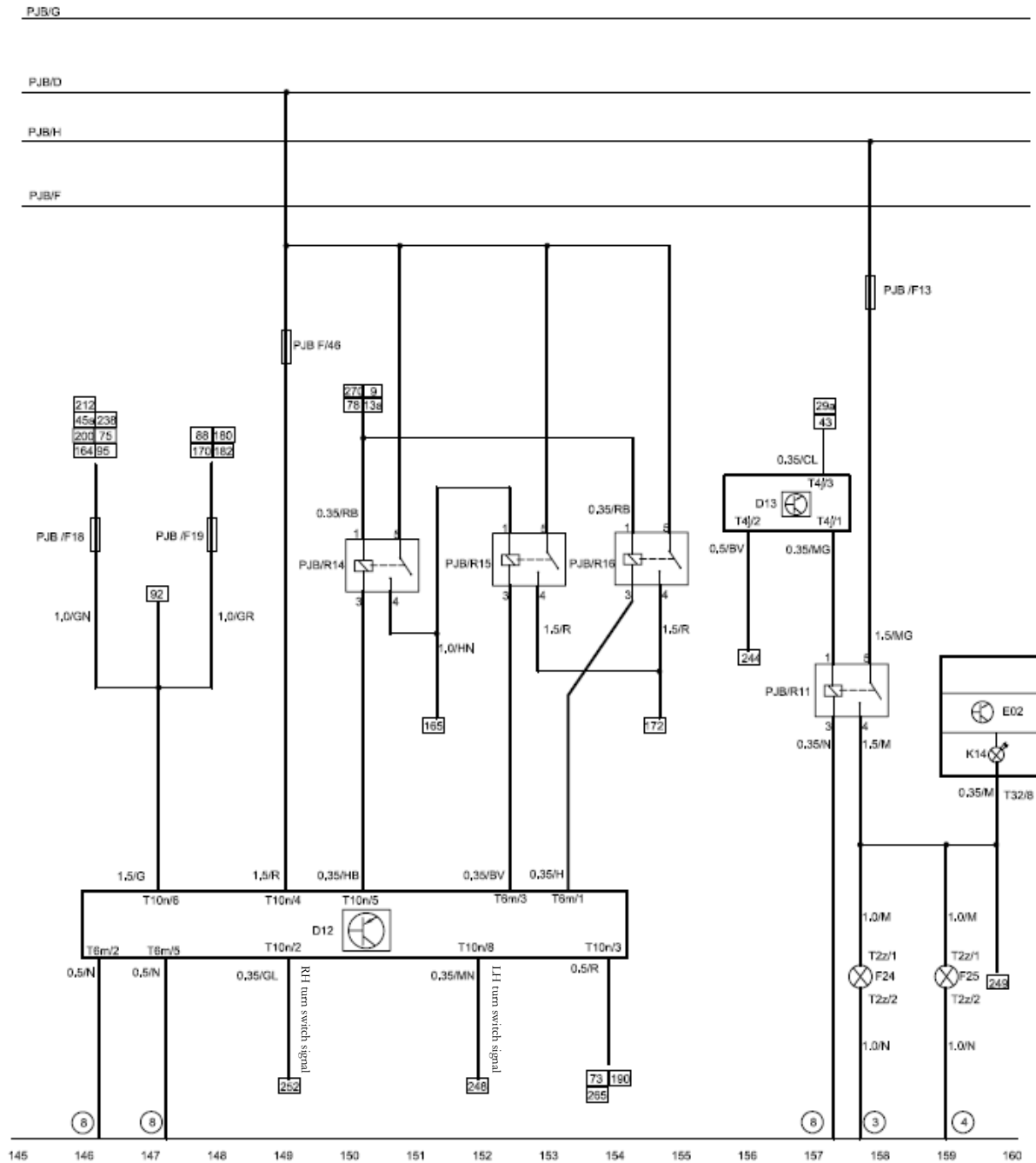

14. Diagram of light control switch circuit

- | | | | |
|--------|--|--------|--|
| D12- | light combination control switch | PJB G- | connection, dashboard fuse box stud |
| D13- | fog light control switch | PJB F- | connection, dashboard fuse box stud |
| F24- | FL fog light | PJB H- | connection, dashboard fuse box stud |
| F25- | FR fog light | EJB- | engine compartment fuse box |
| T10n- | light combination switch connector, 10-hole, white | PJB- | dashboard fuse box |
| T6m- | light combination switch connector, 6-hole, white | EJB A- | connection, engine compartment fuse box connected to |
| T4j- | fog light switch connector, 4-hole, black | | positive pole of battery |
| K14- | front fog light indication in combination instrument | ③- | earth point on FL engine compartment |
| T2z- | front fog light connector, 2-hole, black | ④- | earth point on FR engine compartment |
| E02- | combination instrument | ⑧- | lower earth point of main cable on LH pillar A |
| T32- | combination instrument connector, 32-hole, blue | | |
| PJB D- | connection, dashboard fuse box stud | | |

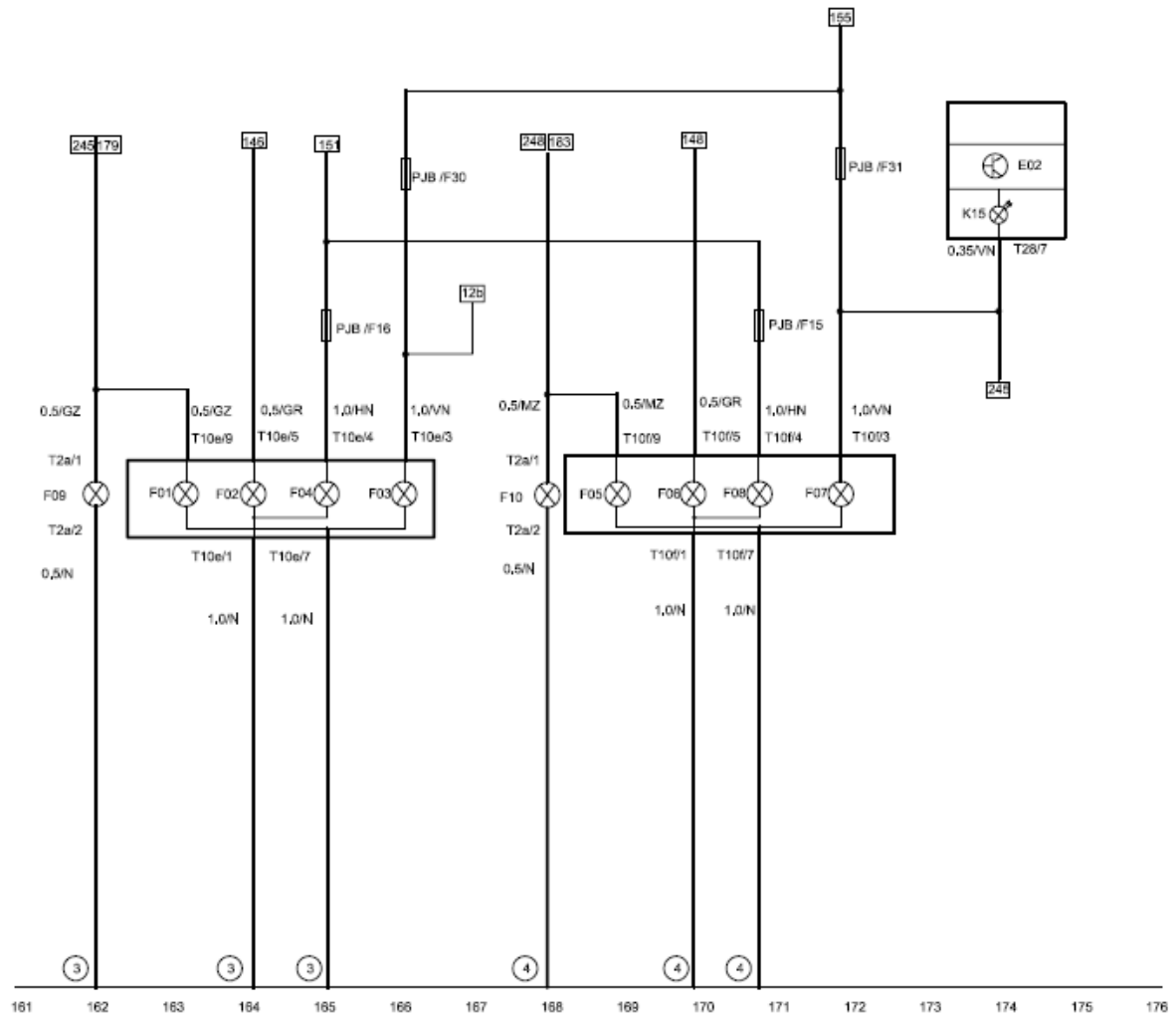

15. Diagram of front headlamp and side turning lamp circuit

T10e-	FL headlamp connector, 10-hole, black	F06-	FR position lamp
T10f-	FR headlamp connector, 10-hole, black	F07-	FR high beam
F01-	FL turning lamp	F08-	FR low beam
F02-	FL position lamp	E02-	combination instrument
F03-	FL high beam	③-	earth point on FL engine compartment
F04-	FL low beam	④-	earth point on FR engine compartment
K15-	high beam indication signal in combination instrument	PJB D-	connection, dashboard fuse box stud
T28-	combination instrument connector, 28-hole, black	PJB G-	connection, dashboard fuse box stud
T2a-	side turning lamp connector, 2-hole, black	PJB F-	connection, dashboard fuse box stud
F09-	LH turning lamp	PJB H-	connection, dashboard fuse box stud
F10-	RH turning lamp	PJB-	dashboard fuse box
F05-	FR turning lamp		

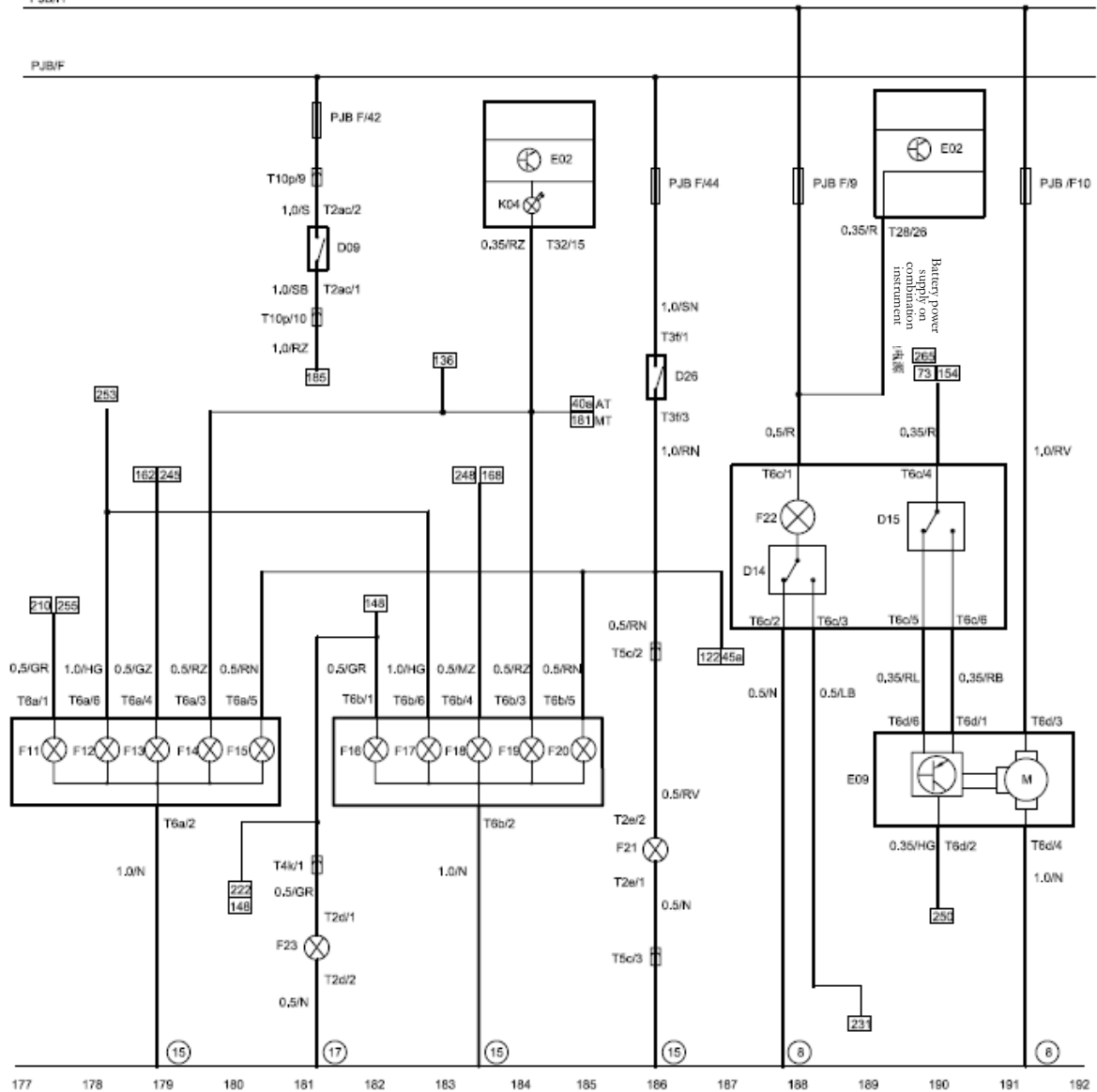

16. Diagram of rear tail light, high-mounted brake lamp, license plate lamp, interior ceiling lamp and sunroof controller circuit

T6a-	RL tail lamp connector, 6-hole, white	F19-	RR back lamp
T6b-	RR tail lamp connector, 6-hole, white	F20-	RR brake lamp
T4k-	connector of RH tail gate cable and main cable, 4-hole, white	T2d-	license plate lamp connector, 2-hole, white
F11-	RL position lamp	E09-	sunroof controller
F13-	RL turning lamp	D15-	sunroof control switch
F14-	RL back lam	F23-	license plate lamp
F15-	RL brake lamp	F22-	interior ceiling lamp
T6d-	sunroof controller connector, 6-hole, gray	D26-	brake switch
T6c-	interior lamp and sunroof switch connector, 6-hole, white	D09-	MT back switch
F12-	RL fog light	○ ₁₅ -	Lower earth point of main cable on RL seat
T2e-	high-mounted brake lamp connector, 2-hole, white	○ ₁₇ -	earth point of main cable on RH pillar C
T3f-	brake lamp connector, 3-hole, white	⑧-	lower earth point of main cable on LH pillar A
T5c-	connector of main cable and LH tail gate cable, 5-hole, black	PJB D-	connection, dashboard fuse box stud
F21-	high-mounted brake lamp	PJB G-	connection, dashboard fuse box stud
D14-	interior lamp switch	PJB F-	connection, dashboard fuse box stud
F16-	RR position lamp	PJB H-	connection, dashboard fuse box stud
F17-	RR fog light	EJB-	engine compartment fuse box
F18-	RR turning lamp	PJB-	dashboard fuse box
		EJB A-	connection, engine compartment fuse box connected to positive pole of battery

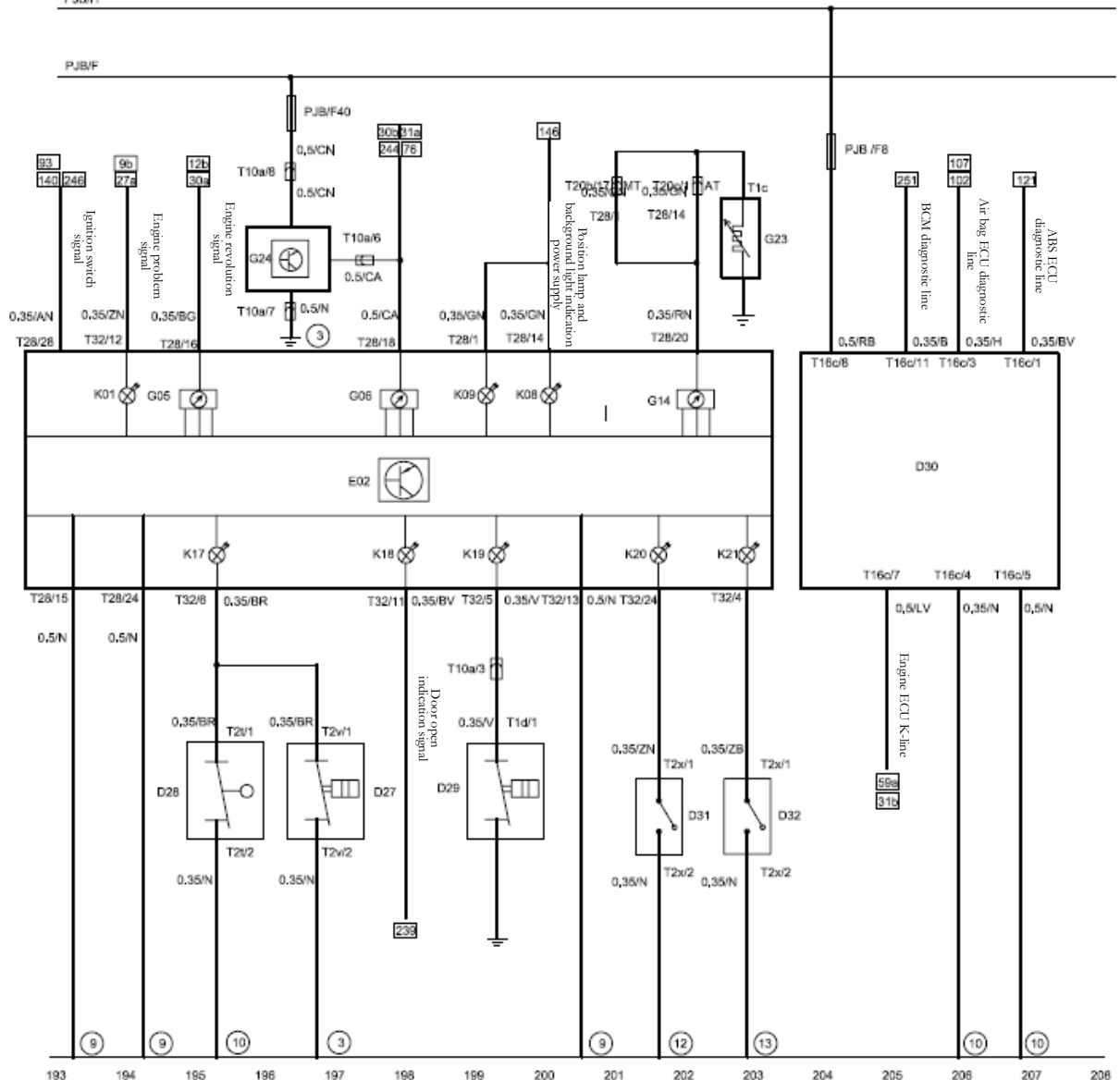

17. Diagram of brake oil level sensor, hand brake, seat belt buckle, engine oil pressure sensor, water temperature sensor and diagnostic interface (MT car speed sensor) circuit

D27-	brake fluid cup level switch	G05-	tachometer in combination instrument
D28-	hand brake switch	T10a-	connector of battery cable to main cable, 10-hole, black
T2t-	hand brake switch connector, 2-hole, black	K01-	engine problem indication lamp in combination instrument
T2v-	brake fluid level sensor connector, 2-hole, gray	D30-	diagnostic interface of electrical parts
K17-	combination instrument hand brake indication signal	T16c-	diagnostic interface connector, 16-hole, black
K18-	combination instrument door open indication signal	G24-	MT speed sensor
D29-	engine oil pressure switch	G23-	water temperature sensor 2
K19-	combination instrument engine oil pressure alarm signal	PJB D-	connection, dashboard fuse box stud
T32-	combination instrument connector, 32-hole, blue	PJB G-	connection, dashboard fuse box stud
K09-	position lamp indication signal in combination instrument	PJB F-	connection, dashboard fuse box stud
K08-	background light illumination in combination instrument	PJB H-	connection, dashboard fuse box stud
E02-	combination instrument	EJB-	engine compartment fuse box
T28-	combination instrument connector, 28-hole, black	PJB-	dashboard fuse box
K20-	driver's side seat belt buckle indication lamp in combination instrument	③-	earth point on FL engine compartment
K21-	front passenger's side seat belt buckle indication lamp in combination instrument	○,12-	lower earth point of main cable on LH pillar B
D31-	driver's seat belt buckle	○,13-	lower earth point of main cable on RH pillar B
D32-	front passenger's seat belt buckle	⑩-	earth point on dashboard cross member
T2x-	seat belt buckle connector, 2-hole, white	⑨-	lower earth point of main cable on RH pillar A
G06-	speedometer in combination instrument	T1c-	water temperature sensor connector, 1-hole
		T1d-	engine oil pressure sensor connector, 1-hole

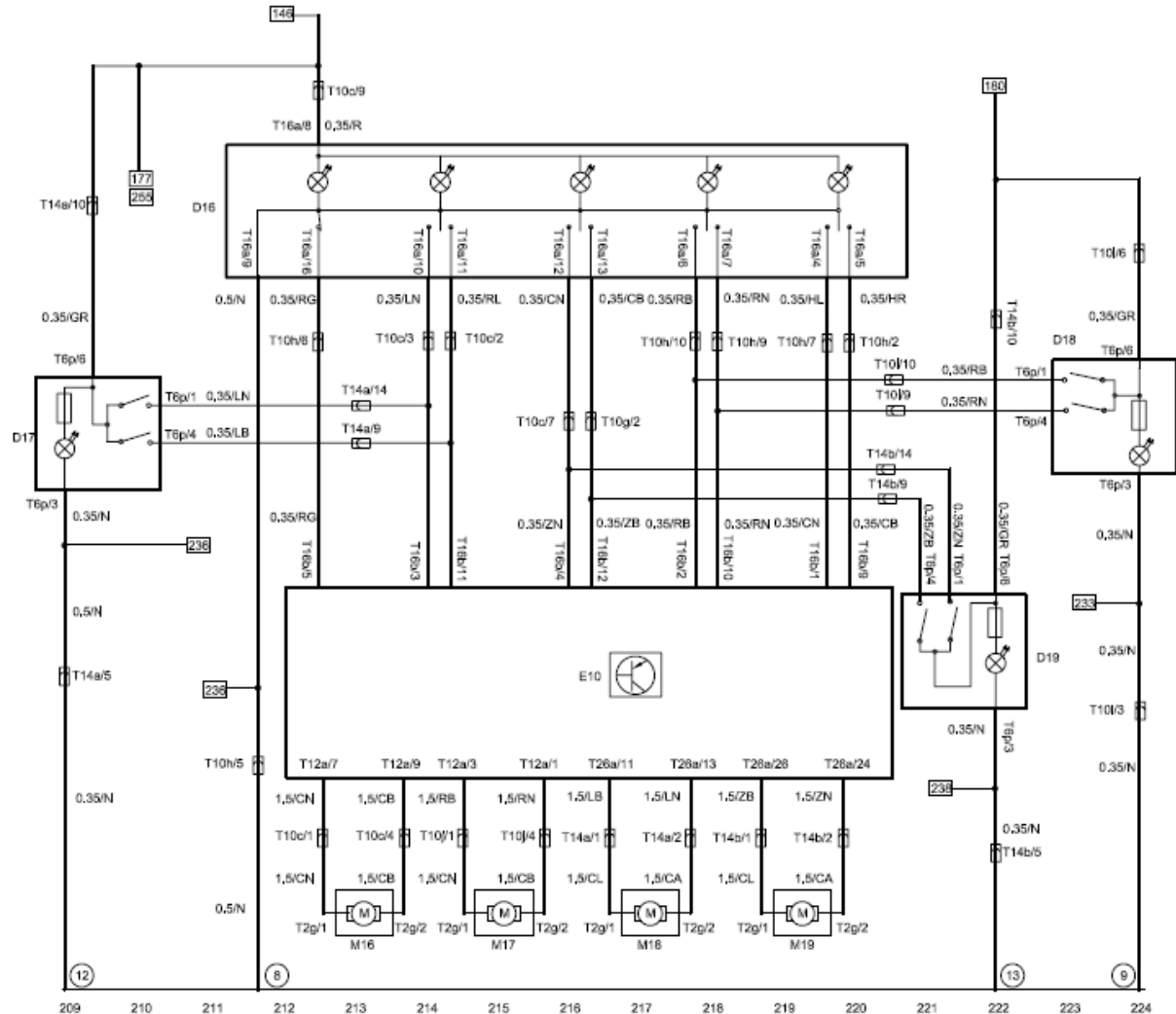

18. Diagram of glass riser switch and glass riser motor circuit

T2g-	glass riser motor connector, 2-hole, white	M17-	FR door glass riser motor
T16a-	FL glass riser power switch connector, 16-hole, brown	M18-	RL door glass riser motor
T16b-	body controller BCM connector, 16-hole, white	M19-	RR door glass riser motor
T12a-	body controller BCM connector, 12-hole, white	E10-	BCM body controller
T14b-	connector of RL door to main cable, 14-hole, white	D17-	RL door glass riser power switch
T26a-	body controller BCM connector, 26-hole, white	D18-	FR door glass riser power switch
T6p-	glass riser switch connector, 6-hole, black	D19-	RR door glass riser power switch
T14a -	connector of RL door to main cable, 14-hole, white	D16-	FR door glass riser power switch
T10g-	connector of FL door to dashboard main cable, 10-hole, orange	⑧-	lower earth point of main cable on LH pillar A
T10h-	connector of FL door to dashboard main cable, 10-hole, black	⑨-	lower earth point of main cable on RH pillar A
T10l-	connector of FR door to dashboard main cable, 10-hole, black	○ ₁₂ -	lower earth point of main cable on LH pillar B
T10j-	connector of FR door to dashboard main cable, 10-hole, white	○ ₁₃ -	lower earth point of main cable on RH pillar B
T10c-	connector of FL door to dashboard main cable, 10-hole, white	PJB D-	connection, dashboard fuse box stud
M16-	FL door glass riser motor	PJB G-	connection, dashboard fuse box stud
		PJB F-	connection, dashboard fuse box stud
		PJB H-	connection, dashboard fuse box
		PJB-	dashboard fuse box

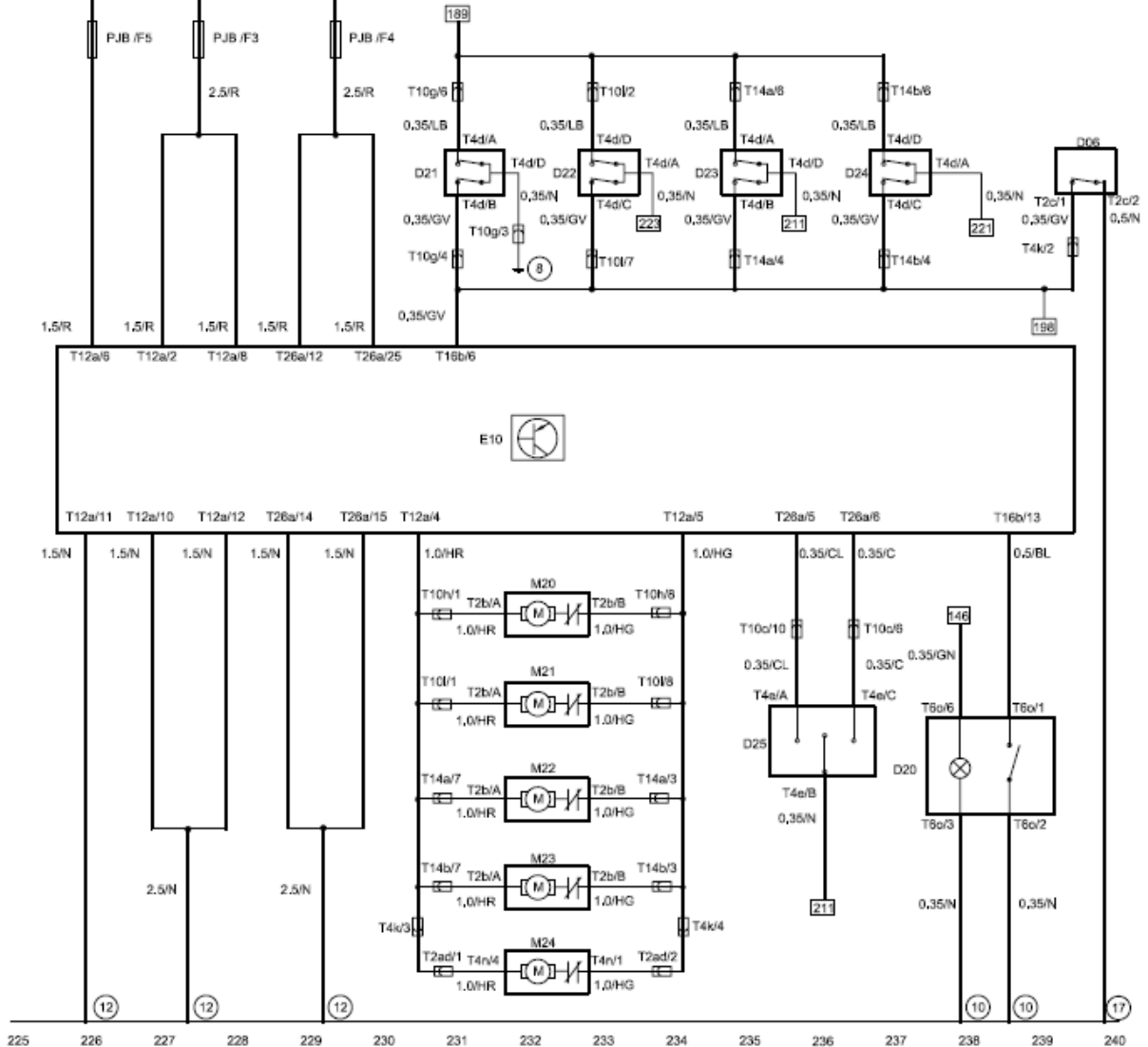

19. Diagram of front door central control switch, door lock motor, alarm lamp module and door micro-switch circuit

T4k- connector of RH tail gate cable and main cable, 4-hole, white
 T2c- tail gate open indication signal connector, 2-hole, white
 T16b- body controller BCM connector, 16-hole, white
 T12a- body controller BCM connector, 12-hole, white
 T26a- body controller BCM connector, 26-hole, white
 T2b- door lock motor connector, 2-hole, black
 T14a- connector of RL door to main cable, 14-hole, white
 T14b- connector of RR door to main cable, 14-hole, white
 T10c- connector of FL door to dashboard main cable, 10-hole, white
 T10g- connector of FL door to dashboard main cable, 10-hole, orange
 T10h- connector of FL door to dashboard main cable, 10-hole, black
 T10l- connector of FR door to dashboard main cable, 10-hole, black
 T10j- connector of FR door to dashboard main cable, 10-hole, white
 D21- FL door micro switch
 D22- FR door micro switch
 E10- BCM controller
 D20- dual-flash switch
 D25- FL door central control switch
 D23- RL door micro switch
 D24- RR door micro switch
 M20- FL door lock motor

M21- FR door lock motor
 ○,12- lower earth point of main cable on LH pillar B
 ○10- earth point of dashboard cross member
 ○8- lower earth point of main cable on LH pillar A
 ○,17- earthing point of main cable on pillar C
 PJB D- connection, dashboard fuse box stud
 PJB G- connection, dashboard fuse box stud
 PJB F- connection, dashboard fuse box stud
 PJB H- connection, dashboard fuse box stud
 EJB- engine compartment fuse box
 PJB- dashboard fuse box
 M22- RL door lock motor
 M23- RR door lock motor
 M24- tail gate lock motor
 T4d- door lock micro switch connector, 4-hole, black
 T4e- FL door central control switch connector, 4-hole, gray
 T6o- alarm lamp module connector, 6-hole, blue
 D06- tail gate open indication switch, 2-hole, white
 T4n- tail gate lock motor connector, 4-hole, black

PJB/G

PJB/D

PJB/H

PJB/F

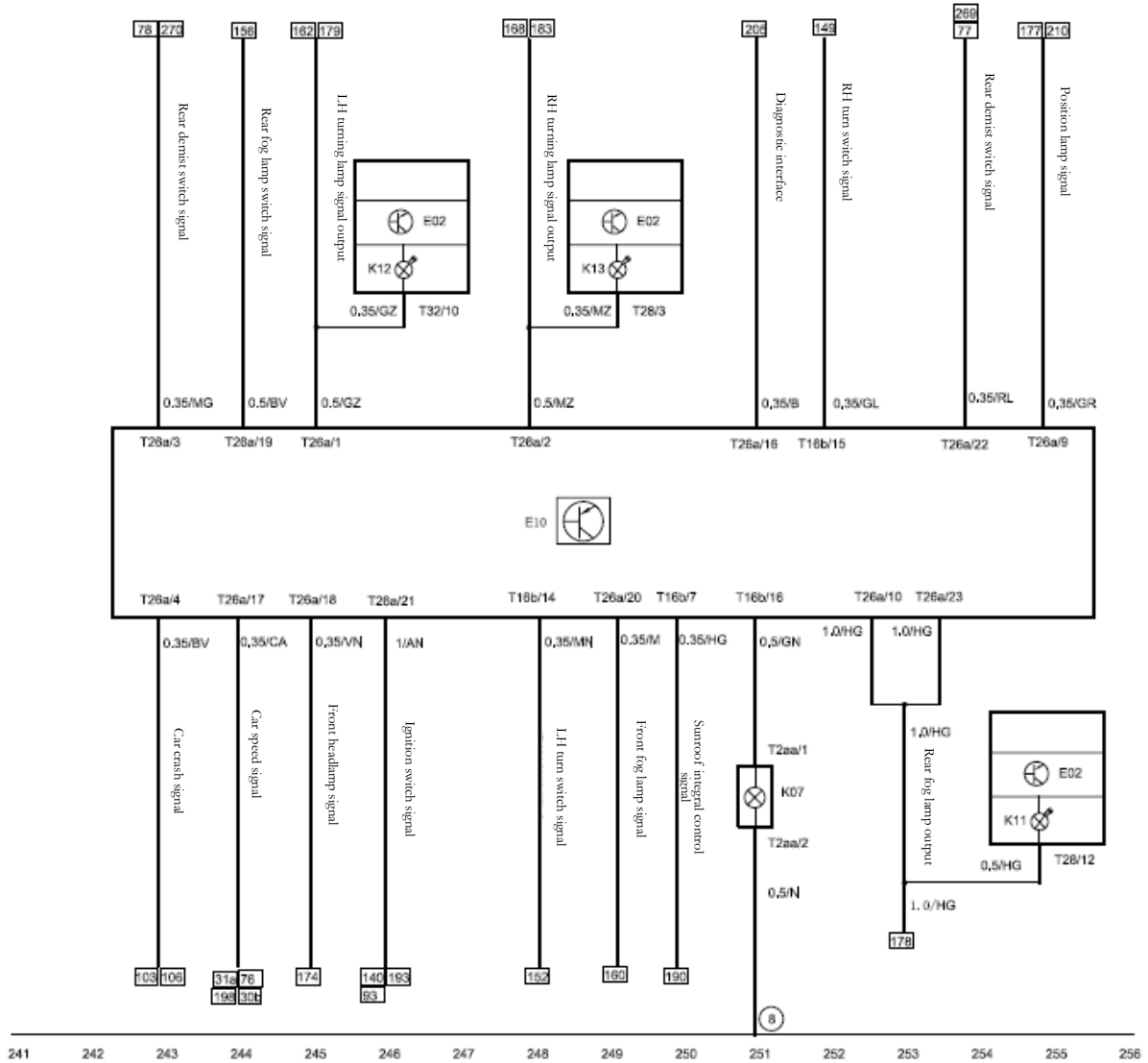

20. Diagram of BCM circuit

- K11- combination instrument rear fog light indication signal
- T28- combination instrument connector, 28-hole, black
- T16b- body controller BCM connector, 16-hole, white
- T12a- body controller BCM connector, 12-hole, white
- T26a- body controller BCM connector, 26-hole, white
- E02- combination instrument
- T32- combination instrument connector, 32-hole, blue
- K12- combination instrument LH turn indication signal
- K13- combination instrument RH turn indication signal
- K07- key illumination ring indication lamp
- T2aa - key illumination ring connector, 2-hole, white
- E10- BCM body controller
- ⑧- lower earth point of main cable on LH pillar A
- PJB D- connection, dashboard fuse box stud
- PJB G- connection, dashboard fuse box stud
- PJB F- connection, dashboard fuse box stud
- PJB H- connection, dashboard fuse box stud
- EJB- engine compartment fuse box
- PJB- dashboard fuse box

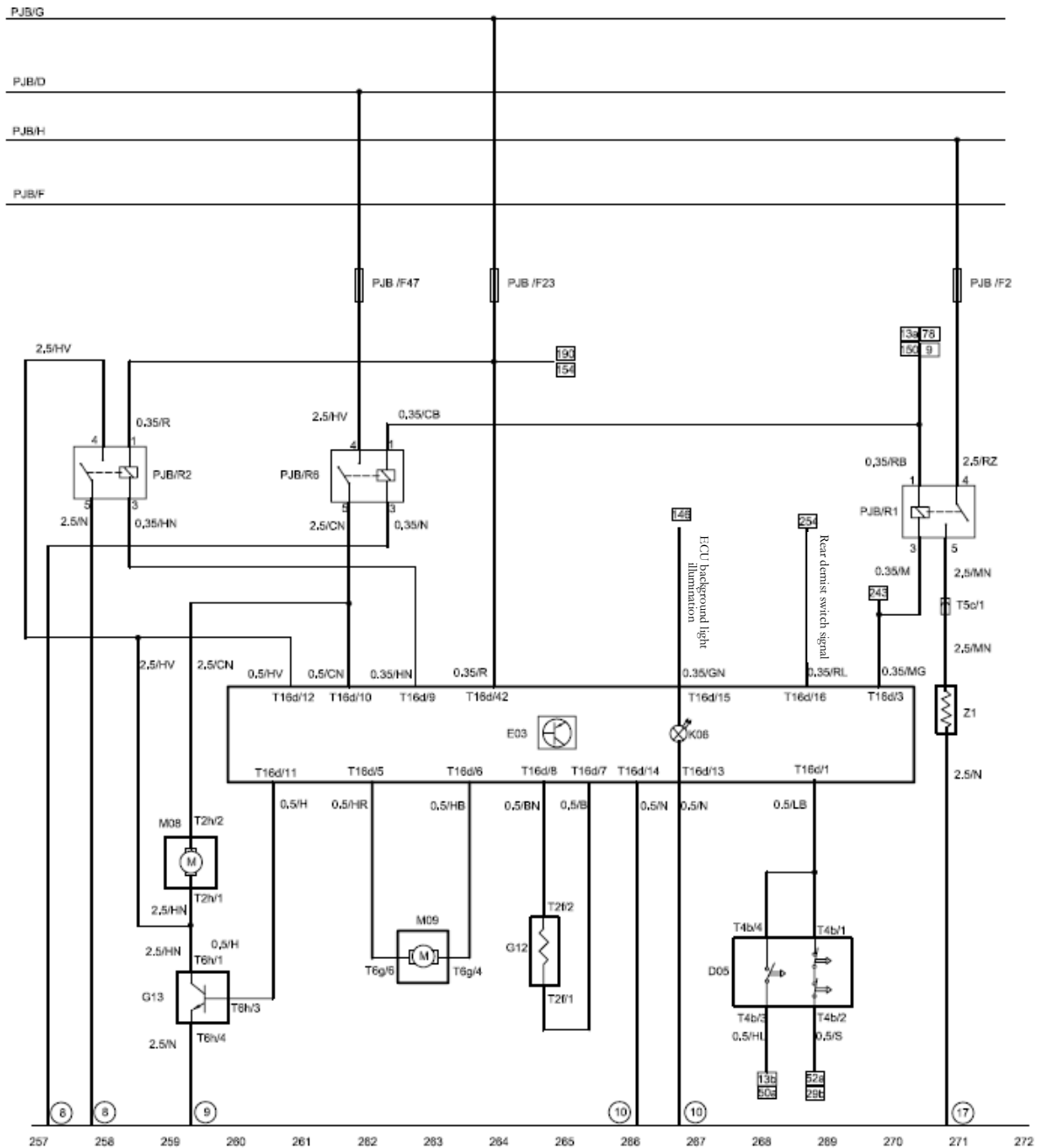

21. Diagram of manual A/C control unit, blower and rear demister circuit

G12- evaporator temperature sensor
T4b- A/C pressure switch connector, 4-hole, green
T5c- connector of main cable and LH tail gate cable, 5-hole, black
K06- background light illumination of A/C control unit
T16d- A/C ECU connector, 16-hole, black
T12b- A/C ECU connector, 12-hole, black
T2f- A/C evaporator sensor connector, 2-hole, white
T6g- fresh air/circulation air module motor connector, 6-hole, green
T2h- blower motor connector, 2-hole, white
T6h- blower speed regulation resistor connector, 6-hole, white
D05- A/C three-state pressure switch
M08- blower motor
M09- fresh air/circulation air module motor
M07- air out module motor

Z1- rear windshield heater
G12- blower speed regulation resistor
E03- power A/C control unit
M06- mixer air gate motor
⑧- lower earth point of main cable on LH pillar A
⑨- lower earth point of main cable on RH pillar A
⑩- earth point on dashboard cross member
④- Earth point on FR engine compartment
○, 17- earth point of main cable on RH pillar C
PJB D- connection, dashboard fuse box stud
PJB G- connection, dashboard fuse box stud
PJB F- connection, dashboard fuse box stud
PJB H- connection, dashboard fuse box stud
EJB- engine compartment fuse box
PJB- dashboard fuse box

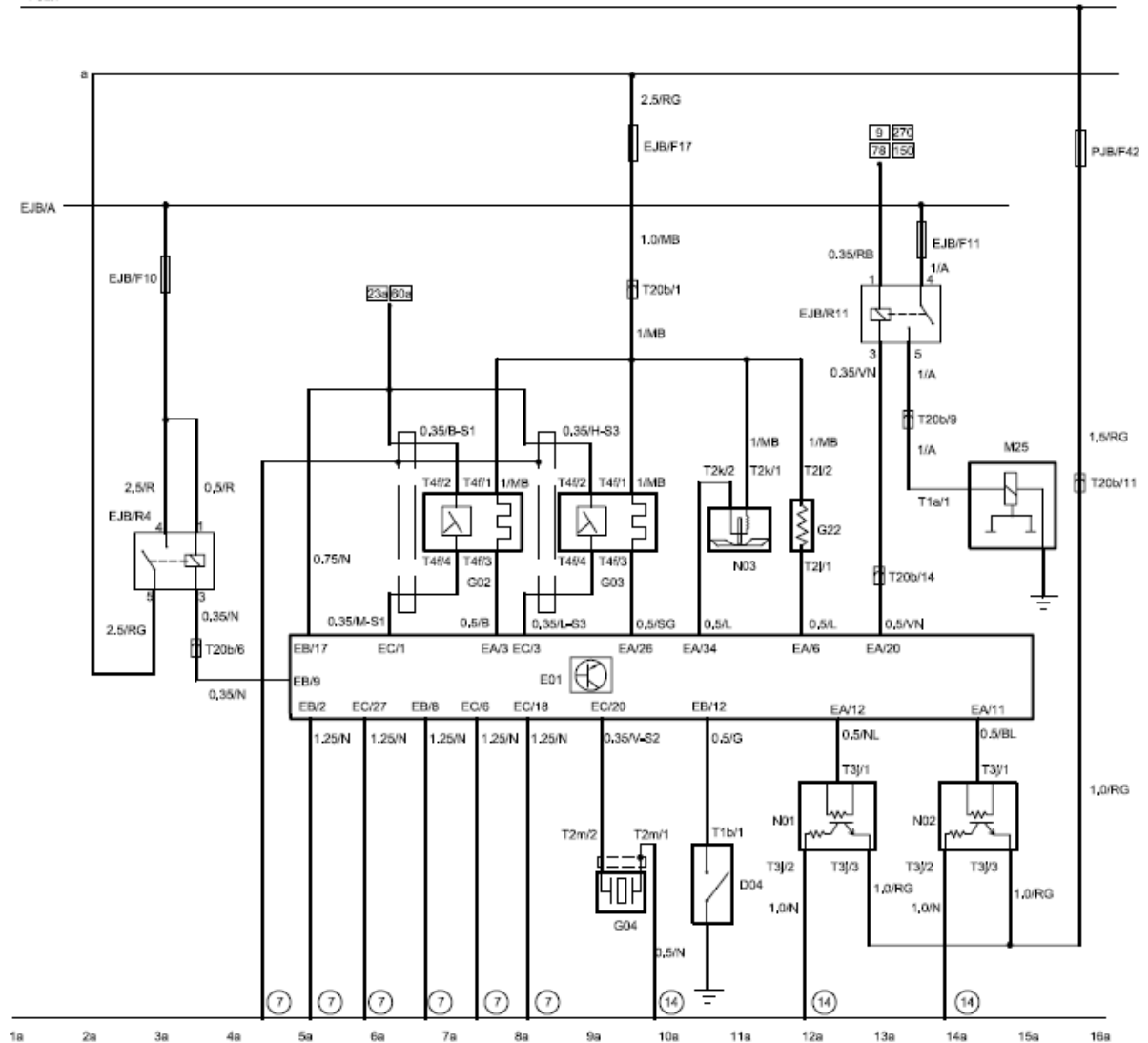

22. Diagram No. 1 of 1.6AT electronic injection unit circuit

a-	main relay power supply	T1b-	power steering switch connector, 1-hole
E01-	1.6AT engine ECU	T4f-	oxygen sensor connector, 4-hole, brown
G22-	EGR valve	T20b-	connector of electronic injection cable and main cable, 20-hole, black
G02-	front oxygen sensor	T1a-	A/C compressor connector, 1-hole, gray
G03-	rear oxygen sensor	T3j-	ignition coil connector, 3-hole
N03-	canister solenoid valve	⑦-	lower earthing point of LH pillar A of AT electronic injection cable
EA-	engine ECU connector, 35-hole, gray	○, ¹⁴ -	earth point of engine body of electronic injection cable
EB-	engine ECU connector, 26-hole, gray	PJB D-	connection, dashboard fuse box stud
EC-	engine ECU connector, 28-hole, gray	PJB G-	connection, dashboard fuse box stud
ED-	engine ECU connector, 30-hole, gray	PJB F-	connection, dashboard fuse box stud
T2k-	canister solenoid valve connector, 2-hole	PJB H-	connection, dashboard fuse box stud
T2l-	EGR valve connector, 2-hole	EJB-	engine compartment fuse box
M25-	A/C compressor	PJB-	dashboard fuse box
T2m-	knock sensor connector, 2-hole	EJB A-	connection, engine compartment fuse box connected to positive pole of battery
G04-	knock sensor		
D04-	power steering switch		
N01-	ignition coil 2/3		
N02-	ignition coil 1/4		

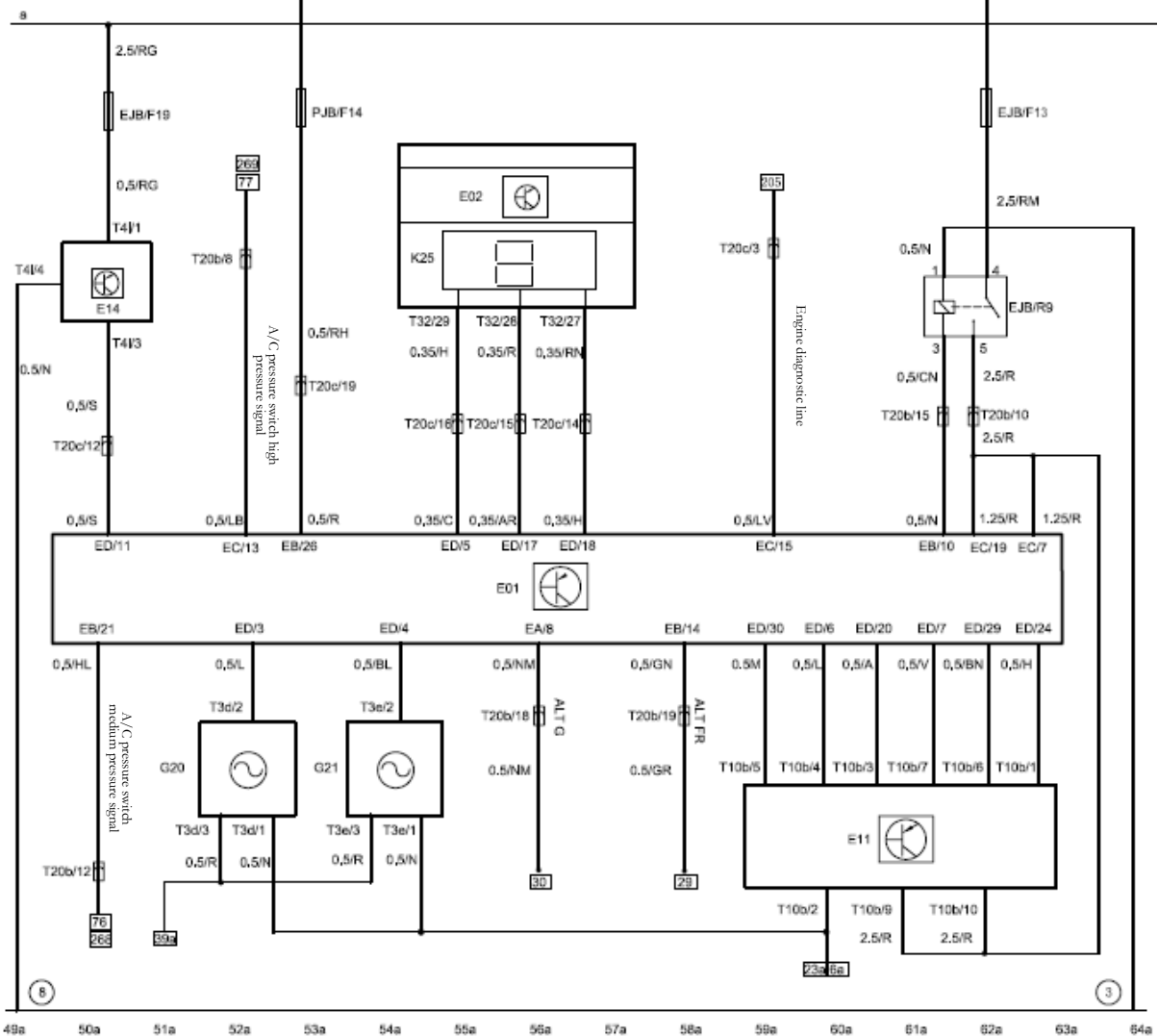

25. Diagram No. 4 of 1.6AT electronic injection unit circuit

T20b- connector of electronic injection cable and main cable, 20-hole, black
 T20c- connector of electronic injection cable and main cable, 20-hole, blue
 E14- immobilizer
 G14- combination instrument water temperature indication
 G20- input shaft position sensor
 G21- output shaft position sensor
 T3d- input shaft sensor connector, 3-hole
 T3e- output shaft position sensor connector, 3-hole
 a- main relay power supply
 T32- combination instrument connector, 32-hole, blue
 T28- combination instrument connector, 28-hole, black
 EA- engine ECU connector, 35-hole, gray
 EB- engine ECU connector, 26-hole, gray
 EC- engine ECU connector, 28-hole, gray
 ED- engine ECU connector, 30-hole, gray

T10b- shift device 2 connector, 10-hole
 T4i- immobilizer connector, 4-hole, black
 E02- combination instrument
 K25- combination instrument LED speed indication signal
 E11- engine gearbox shift device 2
 ③- engine compartment FL earth point
 ⑧- lower earth point of main cable on L.H pillar A
 PJB D- connection, dashboard fuse box stud
 PJB G- connection, dashboard fuse box stud
 PJB F- connection, dashboard fuse box stud
 PJB H- connection, dashboard fuse box stud
 EJB- engine compartment fuse box
 PJB- dashboard fuse box
 EJB A- connection, engine compartment fuse box connected to positive pole of battery

26-27. Details of connector naming

T1a	A/C compressor connector, 1-hole, gray		
T1b	Power steering switch connector, 1-hole	T3h	Washing fluid pump connector, 3-hole, black
T1c	Water temperature sensor connector, 1-hole	T3i	Lighter connector, 3-hole
T1d	Engine oil sensor connector, 1-hole	T3j	Ignition coil connector, 3-hole
T2a	Side turning lamp connector, 2-hole, black	T3k	MT knock sensor connector, 3-hole
T2b	Door lock motor connector, 2-hole, black	T3l	MT throttle valve position sensor connector, 3-hole
T2c	Tail gate open indication signal connector, 2-hole, white	T3m	MT speed sensor connector, 3-hole, black
T2d	License plate connector, 2-hole, white	T4a	Generator connector, 4-hole, black
T2e	High-mounted brake lamp connector, 2-hole, white	T4b	A/C pressure switch connector, 4-hole, white
T2f	A/C evaporator sensor connector, 2-hole, white	T4c	
T2g	Glass riser motor connector, 2-hole, white	T4d	Door lock micro switch connector, 4-hole, white
T2h	Blower motor connector, 2-hole, white	T4e	FL door central controls witch, 4-hole, black
T2i	Bass speaker connector, 2-hole, black	T4f	Oxygen sensor connector, 4-hole, black
T2j	Treble speaker connector, 2-hole, black	T4g	Air flow rate sensor connector, 4-hole, brown
T2k	Canister solenoid valve connector, 2-holes, black	T4h	Throttle valve position sensor connector, 4-hole, black
T2l	EGR valve connector, 2-hole, black	T4i	Back radar sensor connector, 4-hole, brown
T2m	Knock sensor connector, 2-hole	T4j	Fog light switch connector, 4-hole, black
T2n	Nozzle connector, 2-hole	T4k	Connector of RH tail gate cable and main cable, 4-hole, white
T2o	Water temperature sensor connector, 2-hole	T4l	Immobilizer connector, 4-hole, black
T2p	ABS sensor connector, 2-hole, black	T4m	MT stepper motor connector, 4-hole black
T2q	Driver's air bag connector, 2-hole	T4n	Tail gate lock motor connector, 4-hole, black
T2r	Front passenger's air bag connector, 2-hole	T5a	Rear wiper controller connector, 5-hole, gray
T2s	Side air bag connector, 2-hole	T5b	Front wiper motor connector, 5-hole, black
T2t	Hand brake switch connector, 2-hole, black	T5c	Connector of LH tail gate cable and main cable, 5-hole, black
T2u	Side air bag sensor connector, 2-hole, black	T5d	Connector of LH tail gate cable and main cable, 5-hole, brown
T2v	Brake fluid cup level sensor connector, 2-hole, gray	T6a	RL tail gate connector, 6-hole, white
T2w	Seat belt pre-tightening connector, 2-hole, yellow	T6b	RR tail gate connector, 6-hole, white
T2x	Seat belt buckle connector, 2-hole, white	T6c	Sunroof interior ceiling lamp connector, 6-hole, white
T2y	Horn connector, 2-hole, black	T6d	Sunroof controller connector, 6-hole, gray
T2z	Front fog light connector, 2-hole, black	T6e	A/C mixer air gate motor connector, 6-hole, green
T2aa	Ignition key illumination ring connector, 2-hole, white	T6f	A/C air out module motor connector, 6-hole, green
T2ab	MT ignition coil connector, 2-hole, black	T6g	A/C circulation air gate motor connector, 6-hole, green
T2ac	MT back switch connector, 2-hole, black	T6h	Blower speed regulation resistor connector, 6-hole, white
T2ad	Connector of RH tail gate cable and tail gate lock cable, 2-hole, white	T6i	Power rearview mirror connector, 6-hole, white
T3a	Connector of back radar and main cable, 3-hole	T6j	Stepper motor connector, 6-hole, black
T3b	Crankshaft position sensor connector, 3-hole	T6k	Steering wheel volume control switch connector, 6-hole, white
T3c	Camshaft position sensor connector, 3-hole	T6l	Electronic clock connector, 6-hole, black
T3d	Input shaft connector, 3-hole	T6m	Light combination switch connector, 6-hole, white
T3e	Output shaft connector, 3-hole	T6n	Fuel pump connector, 6-hole, brown
T3f	Brake switch connector, 3-hole	T6o	Alarm lamp module connector, 6-hole, blue
T3g	Radiator fan connector, 3-hole	T6p	Glass riser switch connector, 6-hole, black
T8a	Radio cassette connector A, 6-hole, white		
T8b	Radio cassette connector B, 8-hole, white		
T8c	Shift handle speed indication lamp connector, 8-hole, white		
T10a	Connector of battery cable and main cable, 10-hole, black		
T10b	Gearbox shift device connector 1, 10-hole, 色		
T10c	Connector of FL door and main cable, 10hole, white		
T10d	Gearbox shift device connector 2, 10-hole, 色		
T10e	FL headlamp connector, 10-hole, black		
T10f	FR headlamp connector, 10-hole, black		
T10g	Connector of FL door and main cable, 10-hole, orange		
T10h	Connector of FL door and main cable, 10-hole, black		
T10i	Connector of FR door and main cable, 10-hole, black		
T10j	Connector of FR door and main cable, 10-hole, white		
T10k	Shift controller connector, 10-hole, white		
T10l	Connector of MT electronic injection cable and main cable, 10-hole, black		
T10m	Power rearview mirror switch connector, 10-hole, white		
T10n	Light combination switch connector, 10-hole, white		
T12a	BCM controller connector, 12-hole, white		
T12b	A/C ECU connector, 12-hole, black		
T12c	Wiper switch connector, 12-hole, black		
T13a	Connector of power A/C cable and main cable, 13-hole, white		
T14a	Connector of RL cable and main cable, 14-hole, white		
T14b	Connector of RR cable and main cable, 14-hole, white		
T16a	Connector of power A/C cable and main cable, 13-hole, white		

T16b	FL door cable power window riser switch connector, 16-hole, brown		
T16c	Diagnostic interface connector, 16-hole, black		
T16d	A/C ECU connector, 16-hole, black		
T20a	Back radar ECU connector, 20-hole, black		
T20b	Connector of electronic injection cable and main cable, 20-hole, black		
T20c	Connector of AT electronic injection cable and main cable, 20-hole, blue		
T26a	BCM controller connector, 26-hole, white		
T26b	ABS ECU connector, 26-hole, black		
T28	Combination instrument connector, 28-hole, black		
T30	Dual-loop air bag ECU connector, 30-hole, yellow		
T32	Combination instrument connector, 32-hole, blue		
T50a	6-loop air bag ECU connector, 50-hole, yellow		
T81	MT ECU connector, 81-hole, black		

28-29. Details of electrical appliance naming

A	Battery	E05	6-loop air bag ECU
B	Generator	E06	2-loop air bag ECU
C	Starter	E07	ABS ECU
D01	Ignition switch	E08	Back radar controller
D02	Wiper switch	E09	Sunroof controller
D03		E10	BCM controller
D04	Power steering switch	E11	Gearbox shift device 2
D05	A/C three-state pressure switch	E12	Gearbox shift device 1
D06	Tail gate open indication switch	E13	Shift handle speed indication signal
D07		E14	Immobilizer
D08	Steering wheel radio cassette volume control switch	E15	MT ECU
D09	Back switch	E16	Rear wiper blade controller and motor
D10		E17	Lighter
D11	Power rearview mirror switch	F01	FL turning lamp
D12	Light combination switch	F02	FL position lamp
D13	Fog lamp switch	F03	FL high beam
D14	Interior lamp switch	F04	FL low beam
D15	Sunroof control switch	F05	FR turning lamp
D16	FL door glass riser switch	F06	FR position lamp
D17	RL door glass riser switch	F07	FR high beam
D18	FR door glass riser switch	F08	FR low beam
D19	RR door glass riser switch	F09	LH turning lamp
D20	Dual flash switch	F10	RH turning lamp
D21	FL door micro switch	F11	RL position lamp
D22	FR door micro switch	F12	RL fog light
D23	RL door micro switch	F13	RL turning lamp
D24	RR door micro switch	F14	RL back lamp
D25	Central control switch	F15	RL brake lamp
D26	Brake switch	F16	RR position lamp
D27	Brake oil level indication switch	F17	RR fog light
D28	Hand brake switch	F18	RR turning lamp
D29	Engine oil pressure switch	F19	RR back lamp
D30	OBD diagnostic interface	F20	RR brake lamp
EA	AT engine ECU connector, 35-hole, gray	F21	High-mounted brake lamp
EB	AT engine ECU connector, 26-hole, gray	F22	Interior lamp
EC	AT engine ECU connector, 28-hole, gray	F23	License plate lamp
ED	AT engine ECU connector, 30-hole, gray	F24	FL fog light
E01	Engine ECU	F25	FR fog light
E02	Combination instrument	G01	Fuel level indication in combination instrument
E03	Power A/C ECU	G02	Front oxygen sensor
E04	Electronic clock	G03	Rear oxygen sensor
G04	Knock sensor	K18	Door open indication signal on combination instrument
G05	Tachometer in combination instrument	K19	Engine oil pressure alarm lamp on combination instrument
G06	Speedometer in combination instrument	K20	Driver's seat belt buckle indication signal on combination instrument
G07	Camshaft position sensor	K21	Front passenger's seat belt buckle indication signal on combination instrument
G08	Crankshaft position sensor	K22	Sports mode gear-up indication signal on combination instrument
G09	Water temperature sensor	K23	Sports mode gear-down indication signal on combination instrument
G10	Air flow sensor	K24	Background light of shift handle indication lamp device
G11	Throttle valve position sensor	K25	LED speed indication lamp on combination instrument
G12	Evaporator sensor	K26	Generator charging indication lamp on combination instrument
G13	Blower speed-regulation resistor	M01	Fuel pump and fuel level sensor
G14	Water temperature in combination instrument	M02	Rear windshield wiper motor
G15	Engine oil pressure indication	M03	Front wiper motor
G16	FL wheel speed sensor	M04	Washing liquid pump motor
G17	FR wheel speed sensor	M05	Engine stepper motor
G18	RL wheel speed sensor	M06	A/C mixer air gate motor
G19	RR wheel speed sensor	M07	A/C air out module motor
G20	Input shaft position sensor	M08	Blower motor
G21	Output shaft position sensor	M09	A/C circulation air gate motor
G22	EGR valve	M10	FL door rearview mirror LH & RH adjusting motor
G23	Water temperature sensor	M11	FL door rearview mirror upper and lower adjusting motor
G24	MT speed sensor	M12	FR door rearview mirror LH & RH adjusting motor
H01	Bi-tone horn 1	M13	FR door rearview mirror upper and lower adjusting motor
H02	Bi-tone horn 2	M14	
H03	Radio cassette antenna	M15	
K01	OBD problem indication lamp in combination instrument	M16	FL door power window riser motor
K02	P indication signal	M17	FR door power window riser motor
K03	N indication signal	M18	RL door power window riser motor
K04	R indication signal	M19	RR door power window riser motor

K05	D indication signal	M20	FL door lock motor	
K06	Background lamp for A/C ECU	M21	FR door lock motor	
K07	Ignition key illumination ring indication lamp	M22	RL door lock motor	
K08	Background lamp in combination instrument	M23	RR door lock motor	
K09	Position lamp indication in combination instrument	M24	Tail gate lock motor	
K10	Air bag problem indication lamp in combination instrument	M25	A/C compressor	
K11	Rear fog light indication in combination instrument	N01	Ignition coil 2/3	
K12	LH turn indication in combination instrument	N02	Ignition coil 1/4	
K13	RH turn indication in combination instrument	N03	Canister solenoid valve	
K14	Front fog light indication in combination instrument	N04		
K15	High beam indication in combination instrument	N05	Nozzle 1	
K16	ABS problem lamp indication	N06	Nozzle 2	
K17	Hand brake indication signal in combination instrument	N07	Nozzle 3	
N08	Nozzle 4	17	Earth point of pillar C of RH tail gate cable	
N09	Driver's air bag trigger	18	Earth point of battery cable starter	
N10	Front passenger's air bag trigger			
N11	Driver's air bag trigger			
N12	Driver's air bag trigger			
N13	Front passenger's air bag sensor			
N14	Front passenger's air bag trigger			
N15	Driver's seat belt pre-tightening device			
N16	Front passenger's sat belt pre-tightening device			
R	Radio cassette			
R01				
R02	FL bass speaker			
R03	FL treble speaker			
R04	FR bass speaker			
R05	FL treble speaker			
R06	RR bass speaker			
R07	RL bass speaker			
S01	Back radar sensor 1 (from left to right)		Description of cable lead colors:	
S02	Back radar sensor 2 (from left to right)	C		Orange
S03	Back radar sensor 3 (from left to right)	B		White
S04	Back radar sensor 4 (from left to right)	G		Yellow
V01	Radiator cooling fan	M	Brown	
V02	FL door power rearview mirror	S	Pink	
V03	FR door power rearview mirror	V	green	
Z01	Rear windshield heater	A	Light blue	
1	Negative pole of battery to the earth point on body	L	Blue	
2	Negative pole of battery to the earth point on engine	H	Gray	
3	FL earth point on engine compartment	N	Black	
4	FR earth point on engine compartment	R	Red	
5	Earth point of ABS in water trough	Z	Purple	
6	Earth point of MT electronic injection cable in water trough			
7	Lower earth point of AT electronic injection cable on LH pillar A			
8	Lower earth point of main cable on LH pillar A			
9	Lower earth point of main cable on RH pillar A			
10	Earth point of dashboard cross member			
11	Earth point of air bag ECU			
12	Lower earth point of main cable on LH pillar B			
13	Lower earth point of main cable on RH pillar B			
14	Earth point of electronic injection cable on engine block			
15	Lower earth point of main cable on RL seat			
16	Lower earth point of main cable on RR seat			



SAIPA YADAK

Daroupakhsh St.17th Km Karaj Makhsoos Road-TEHRAN-IRAN

www.saipayadak.org